

KORALP®

**SPACE
FITTERS**

SOLUTIONS DE STOCKAGE ET SÉCHAGE SUR-MESURE

K-DOOR





KORALP®

+ 33 4 76 26 76 84

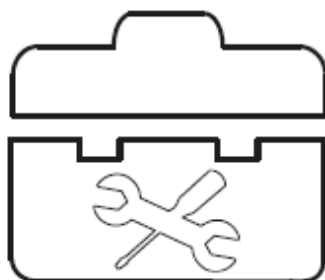
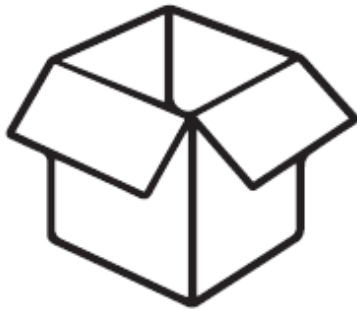

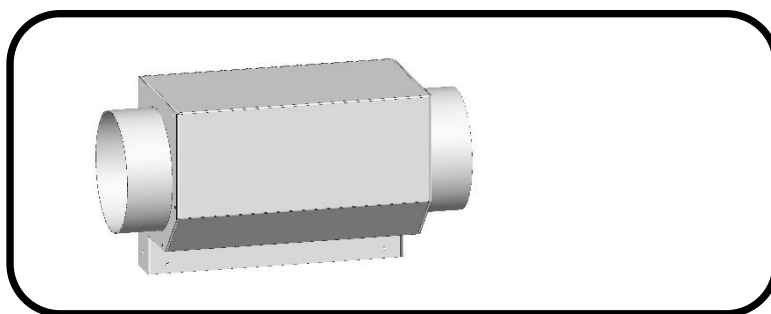
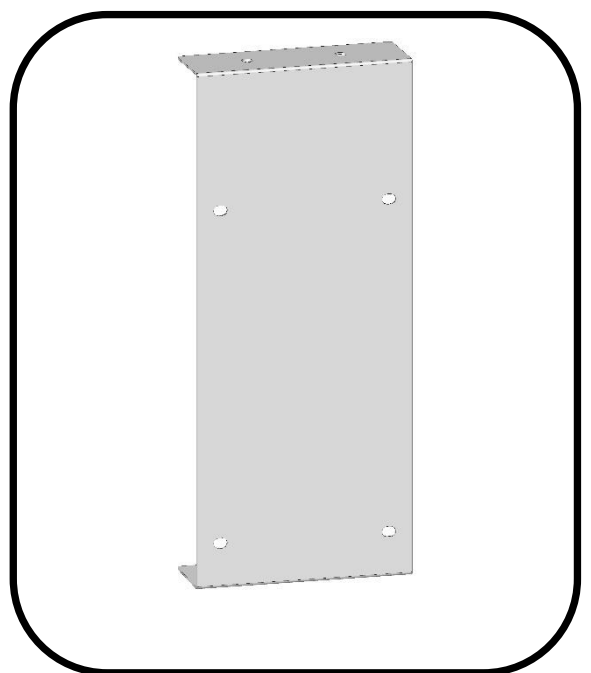
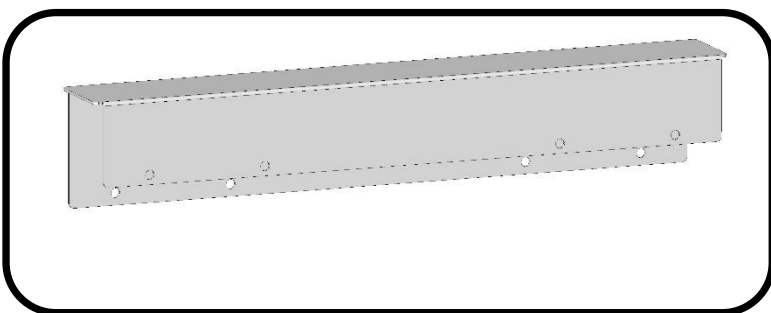
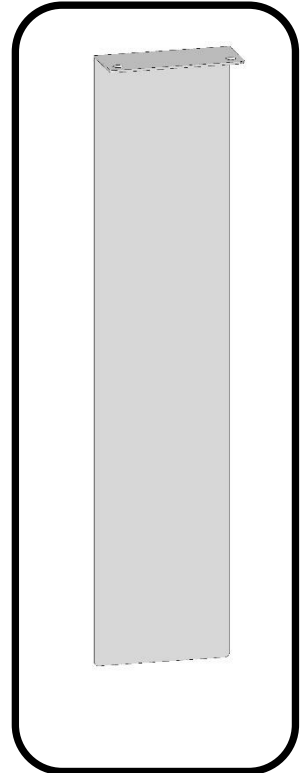
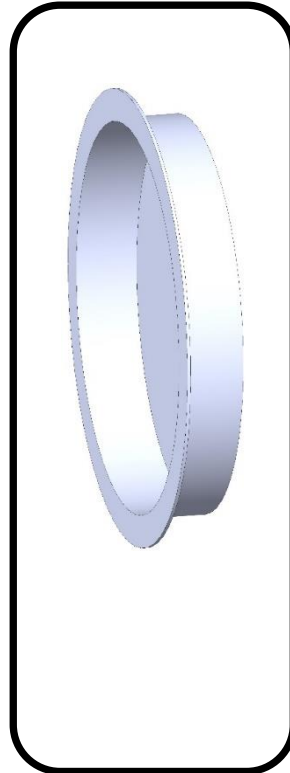
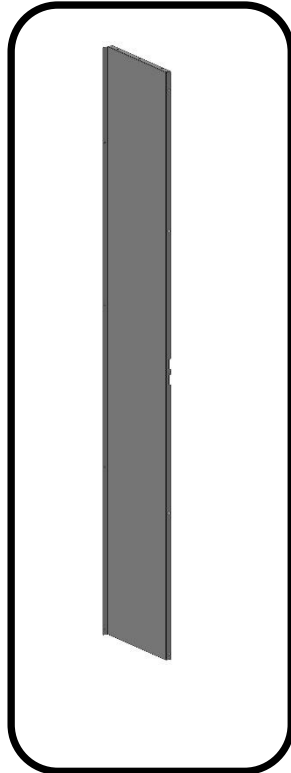
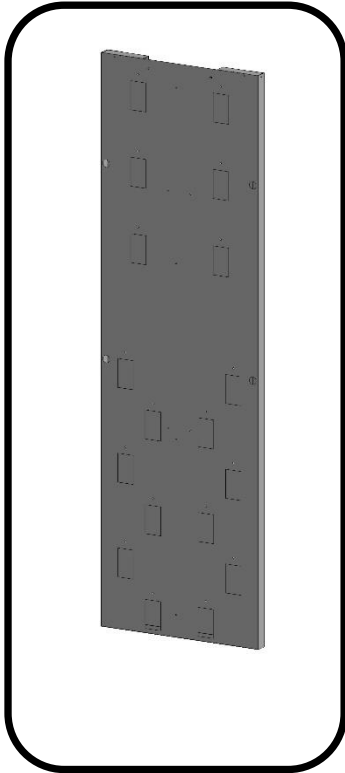
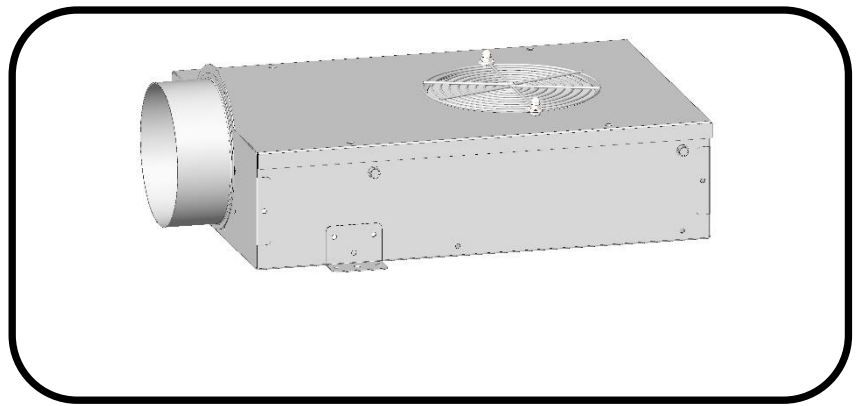
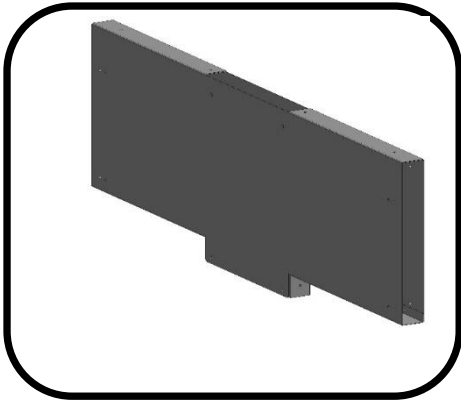

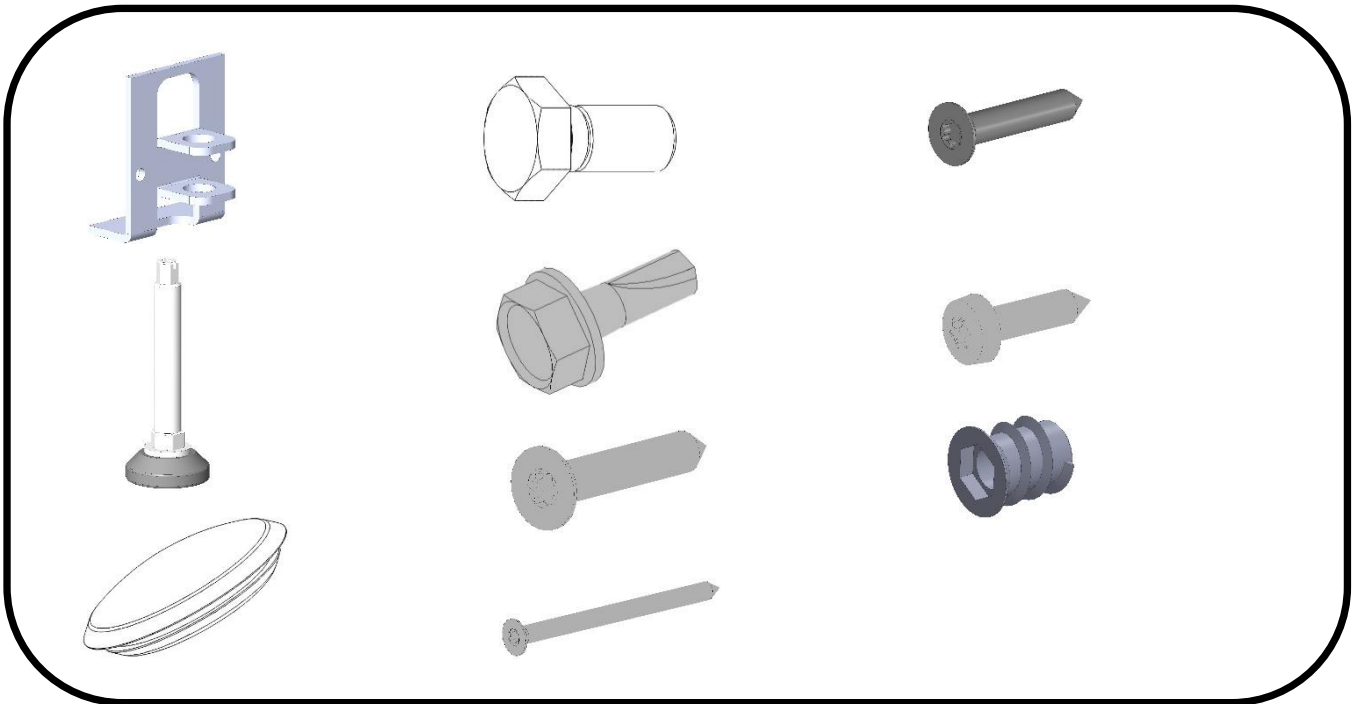
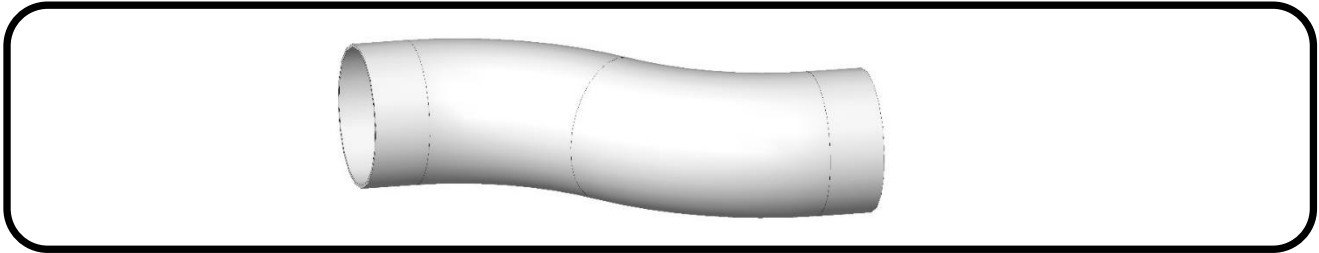
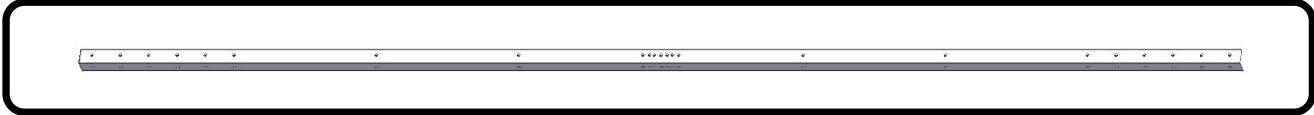
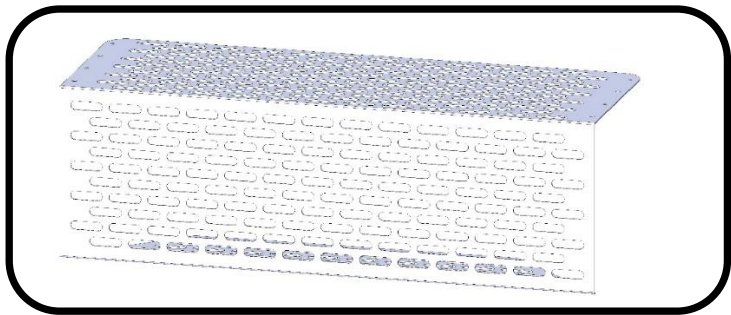
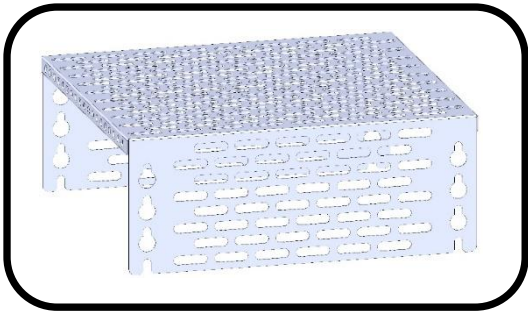

Outillages / Tools :

- **Douille n° 7, n° 8, n° 13 / socket wrench n° 7, n° 8, n° 13**
- **Embout Torx n° T20 / Torx bit n° T20**
- **Embout BTR n° 8 / allen wrench n° 8**
- **Tournevis plat / flat screwdriver**
- **Niveau à bulle / spirit level**
- **Serre-joint / clamp**

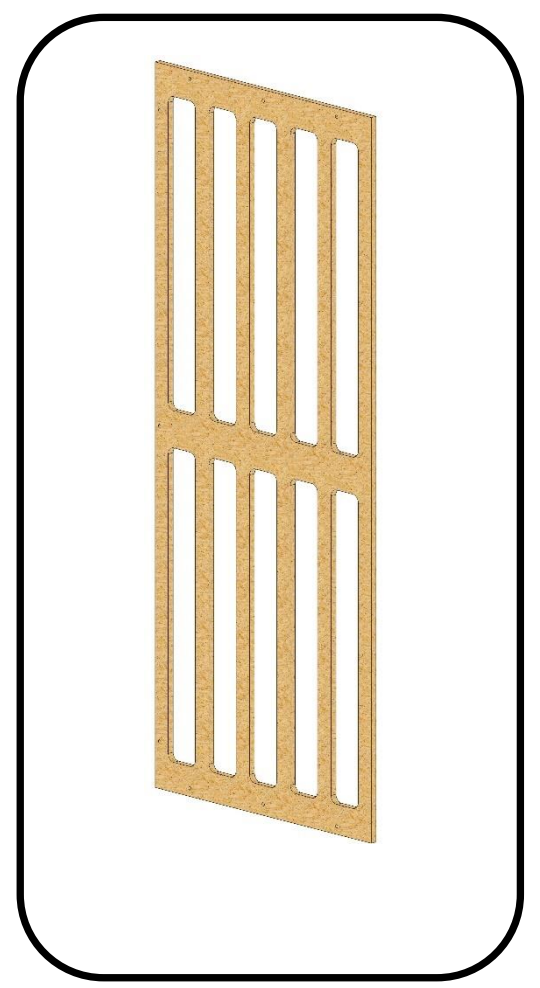
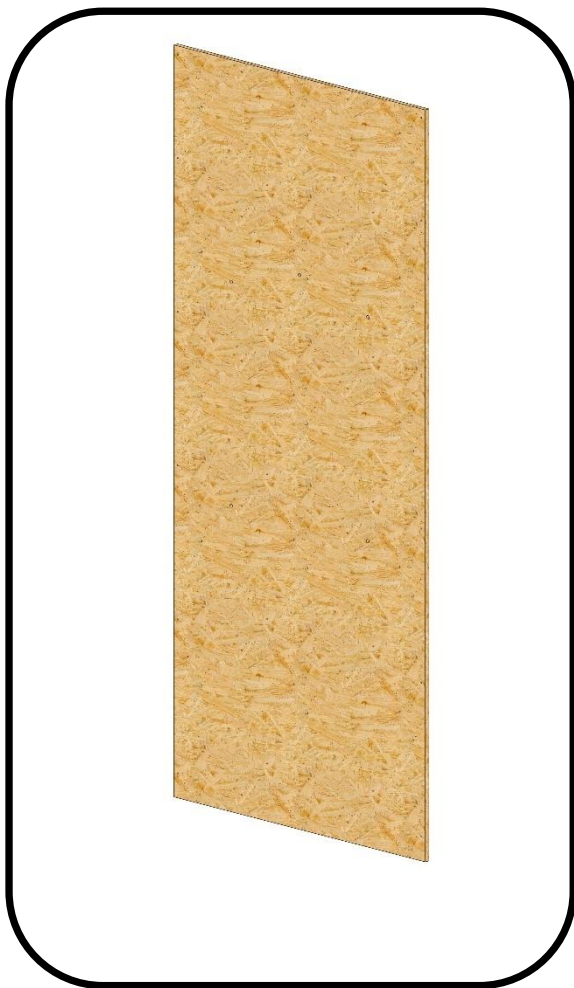
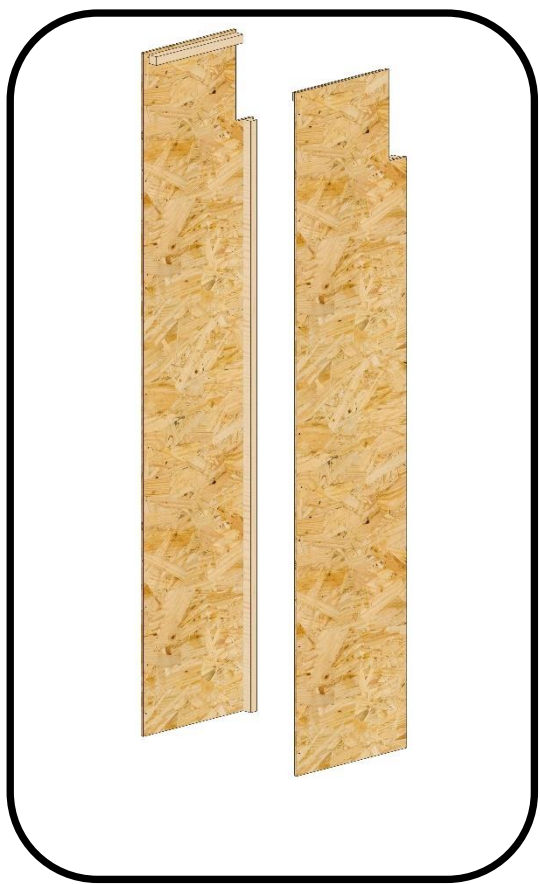

Première partie : Montage d'une armoire

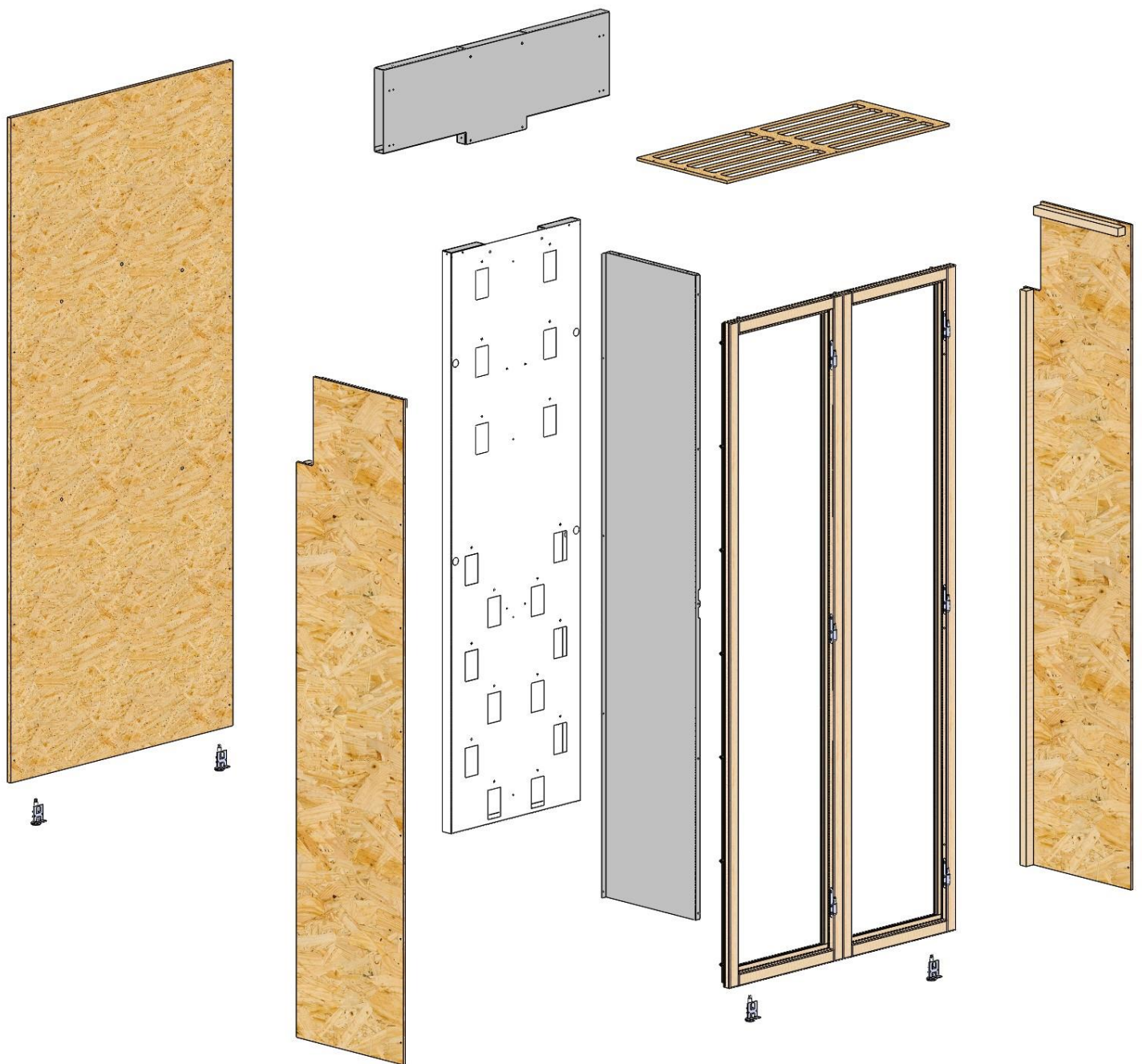

Prérequis :

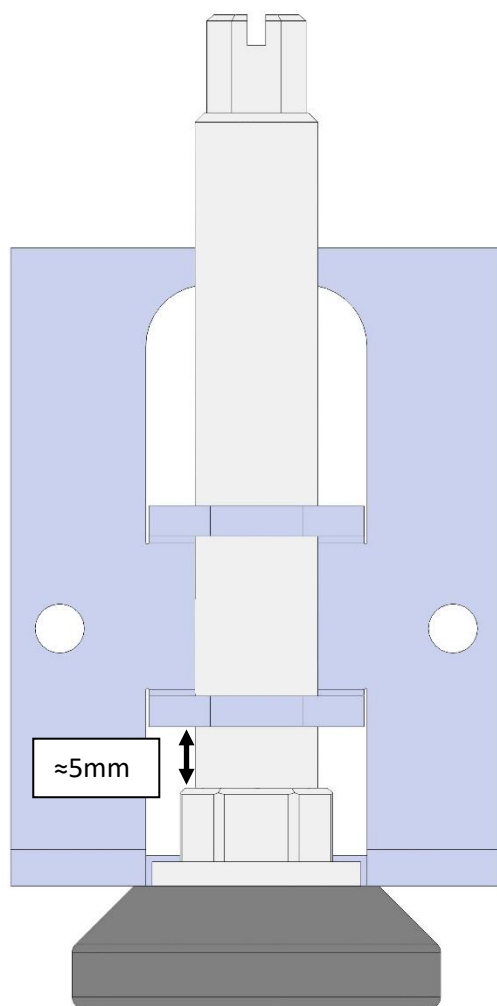
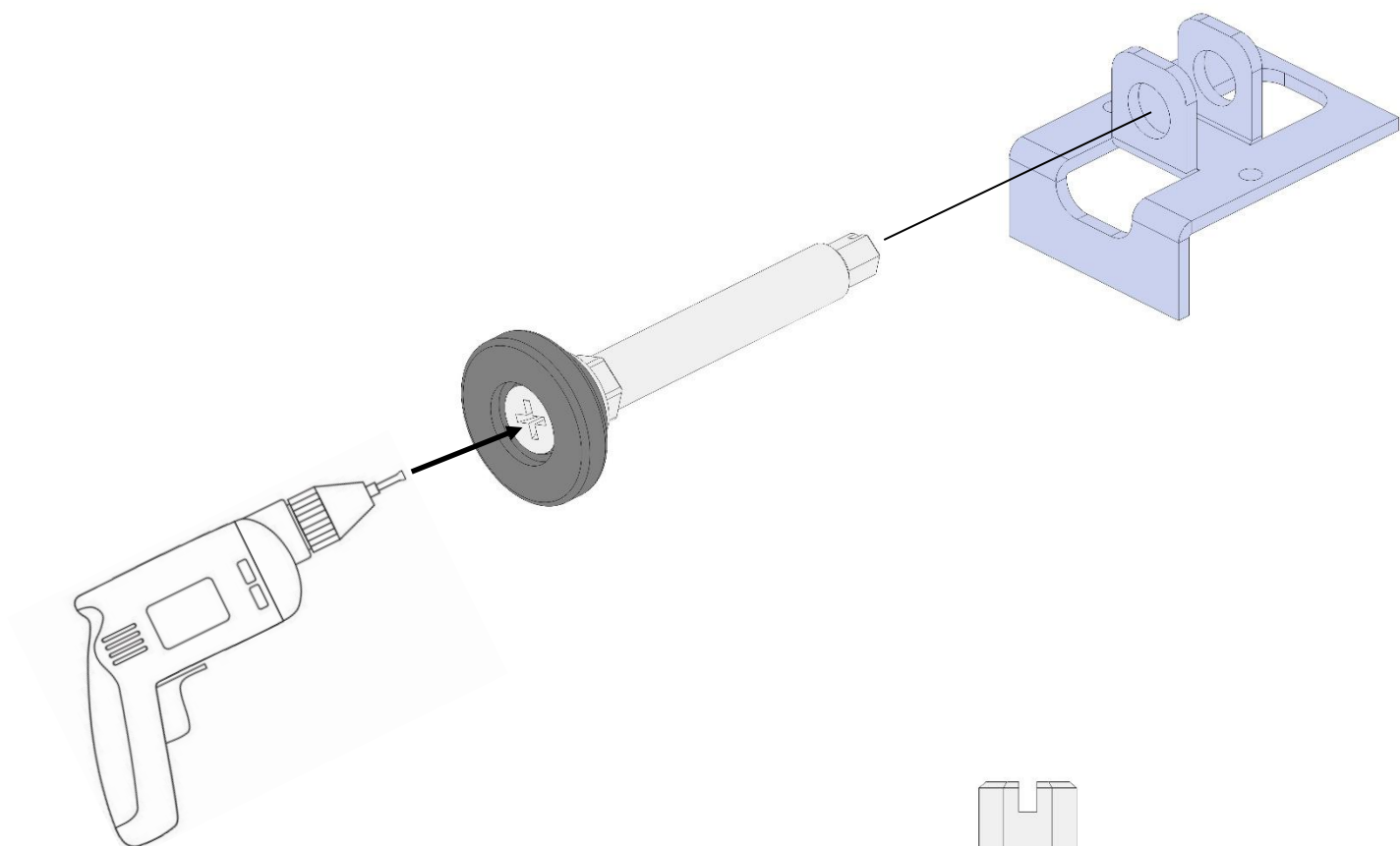

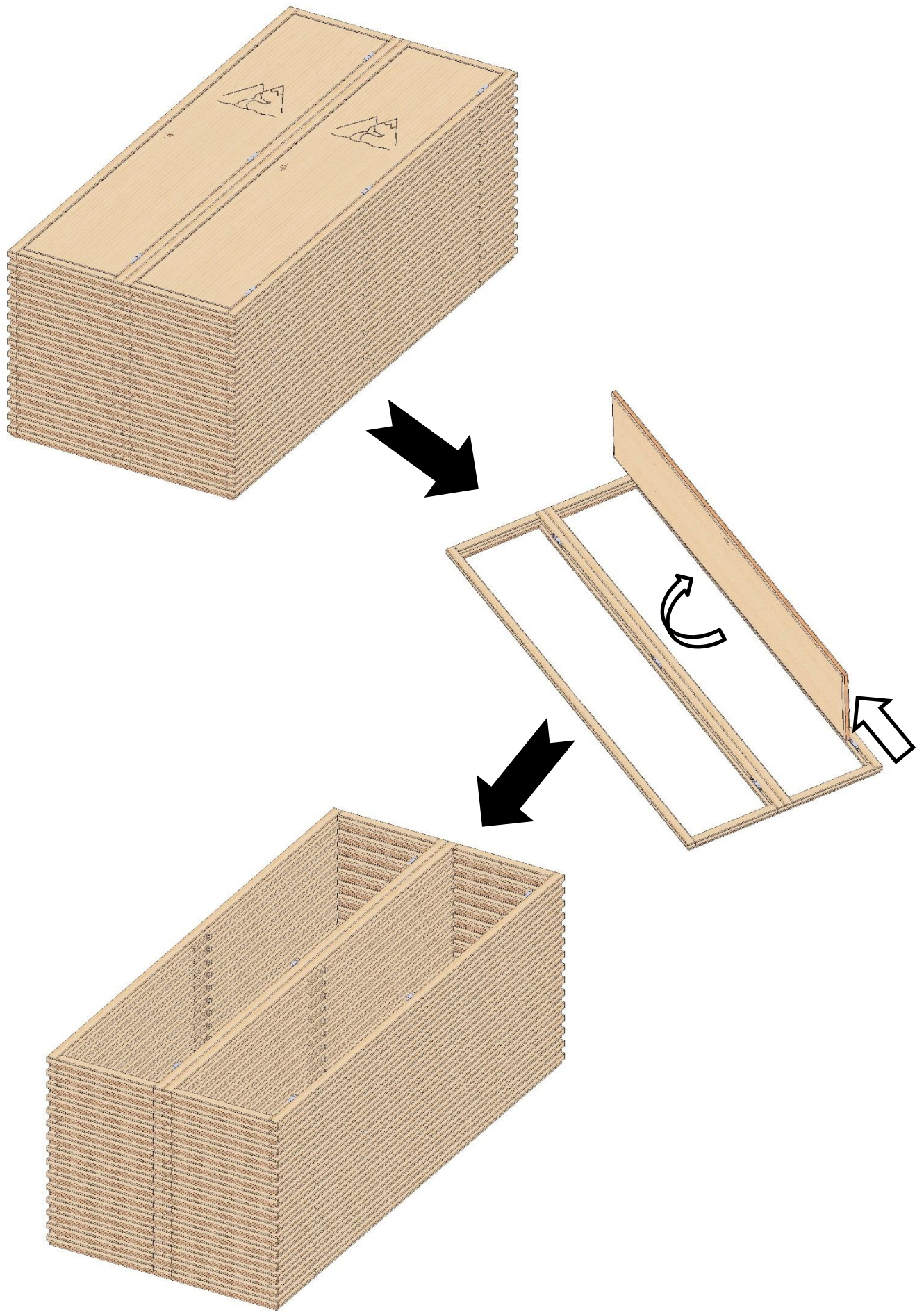

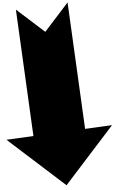
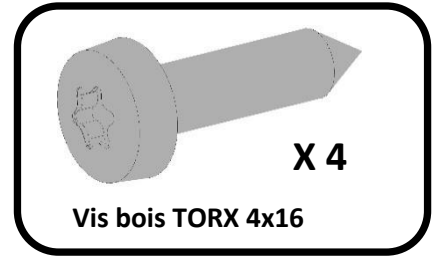
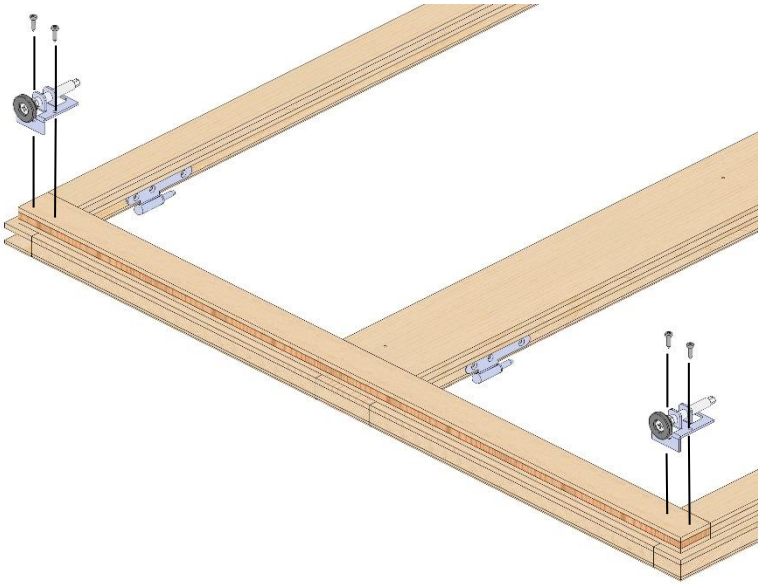

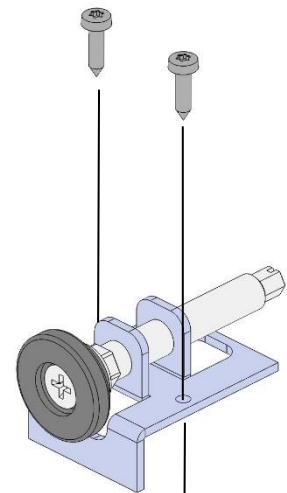
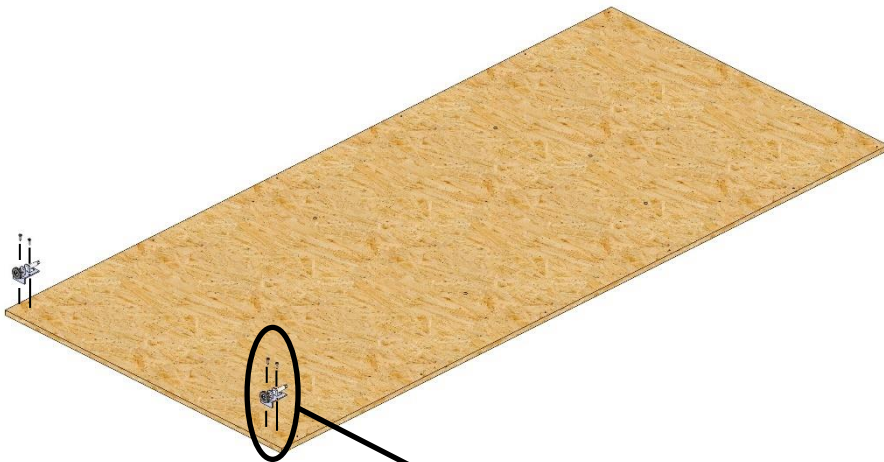
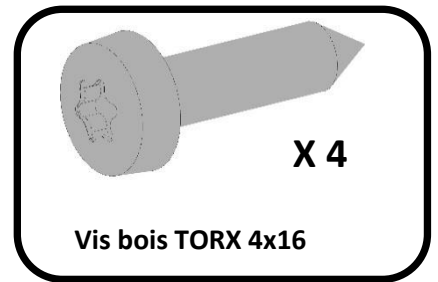
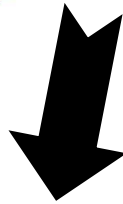
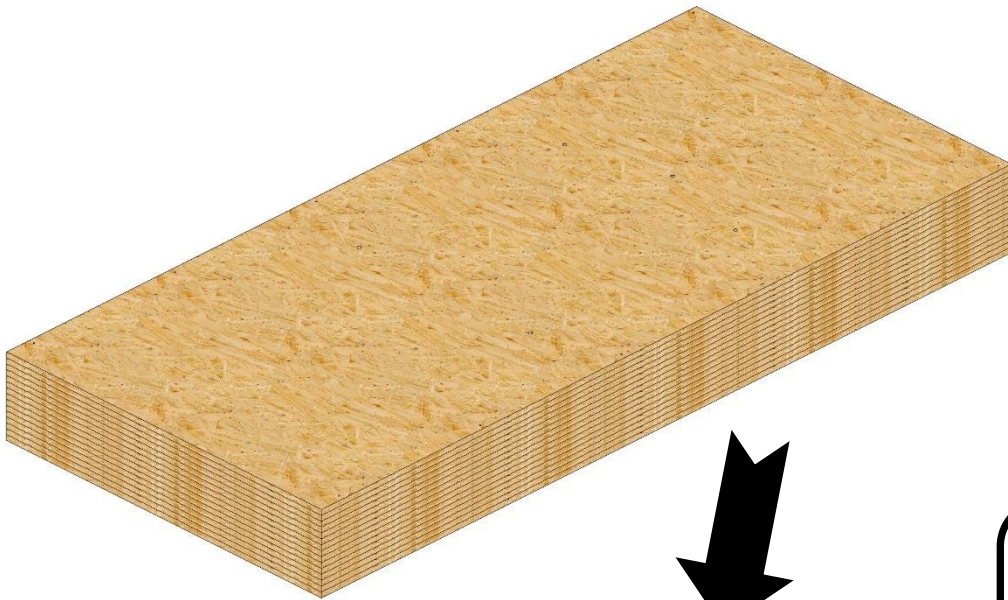

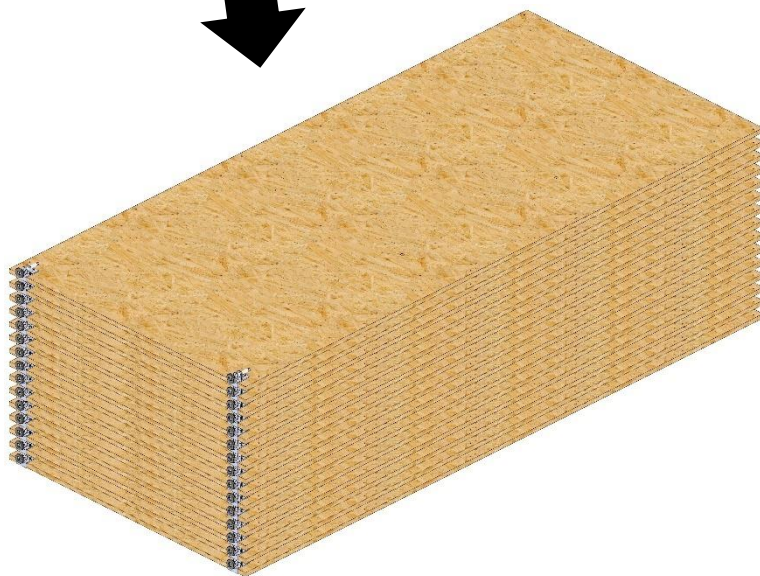
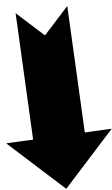
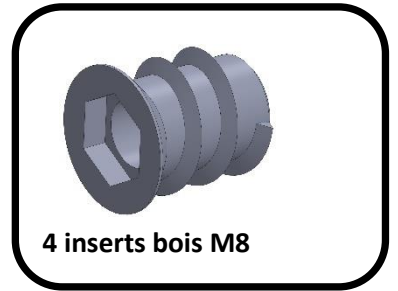
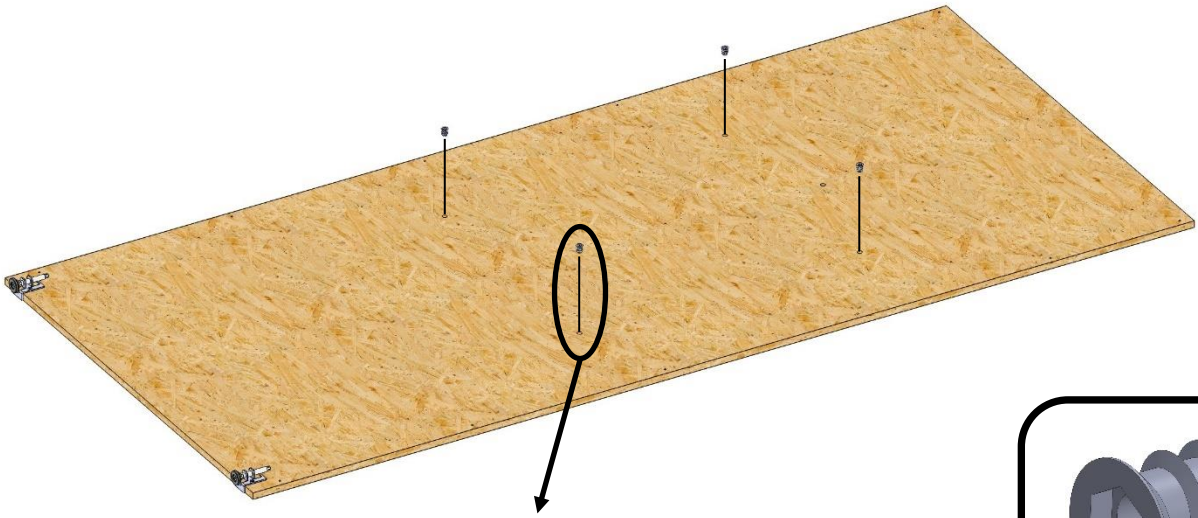

Etape 1 :

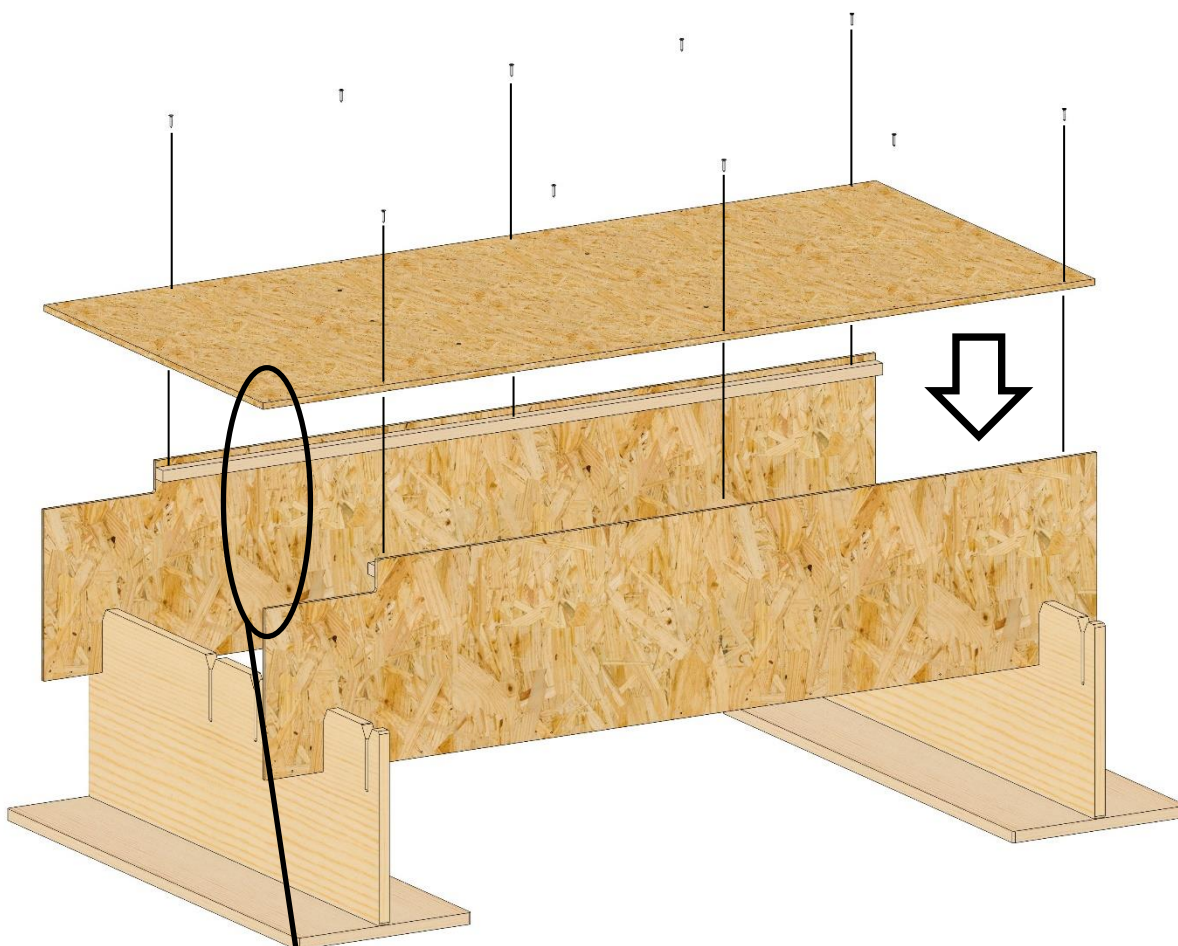
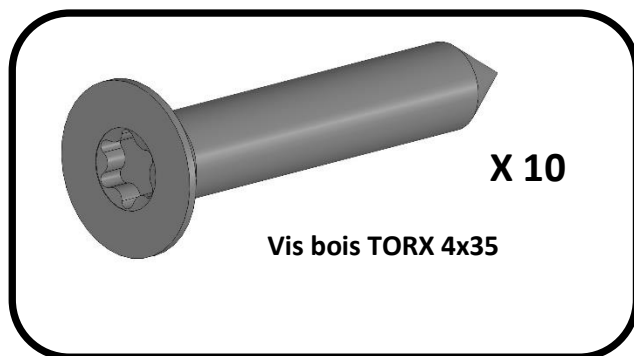

Etape 2 :

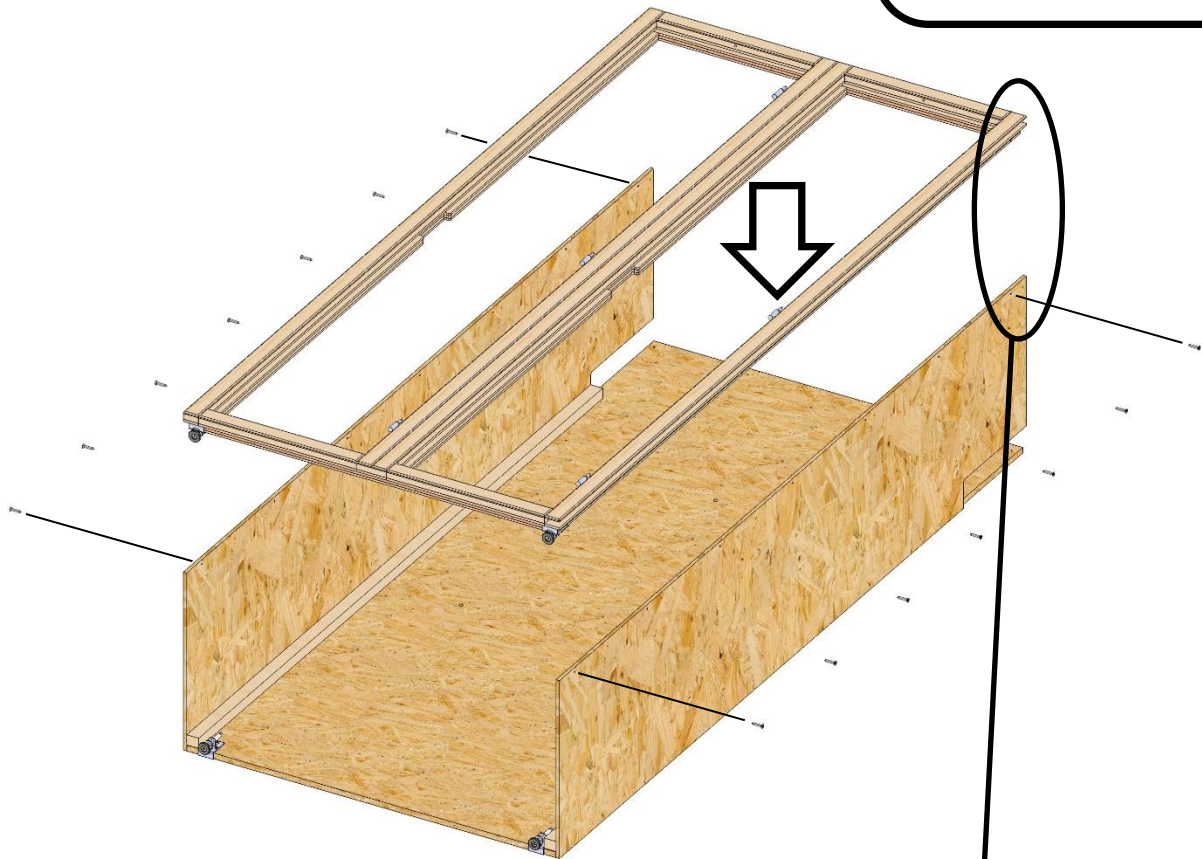
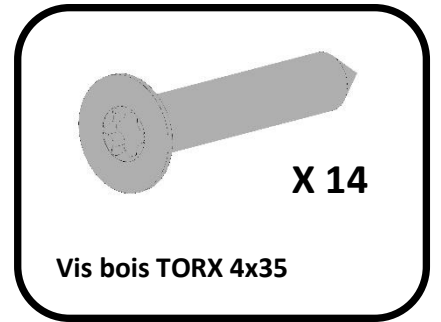

Etape 3 :

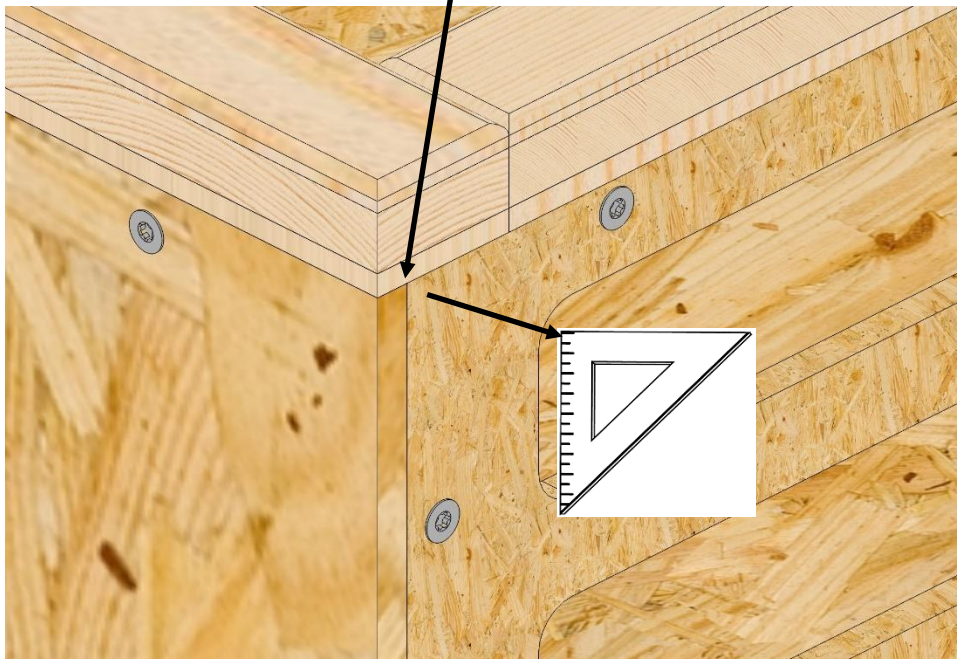
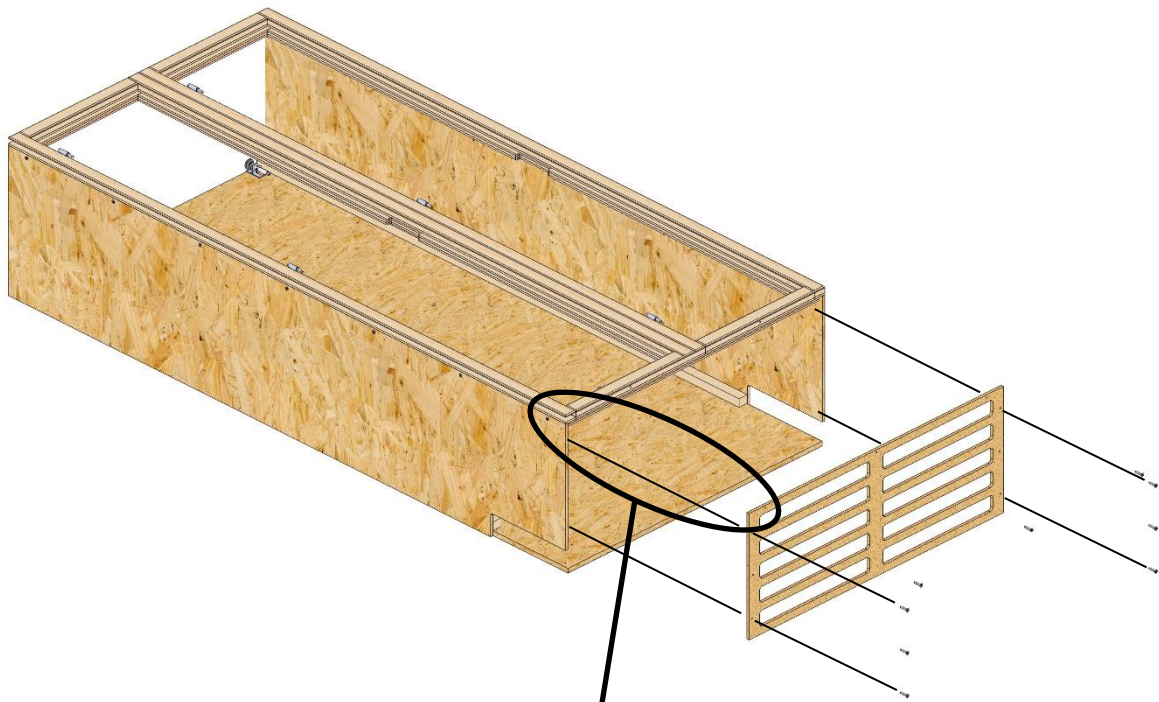
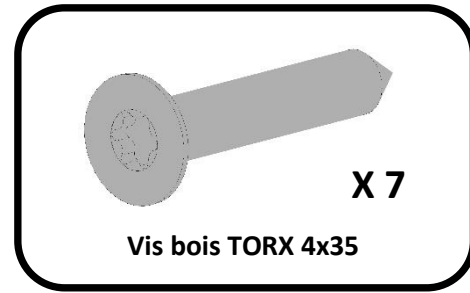

Deuxième partie : Montage d'une série d'armoire

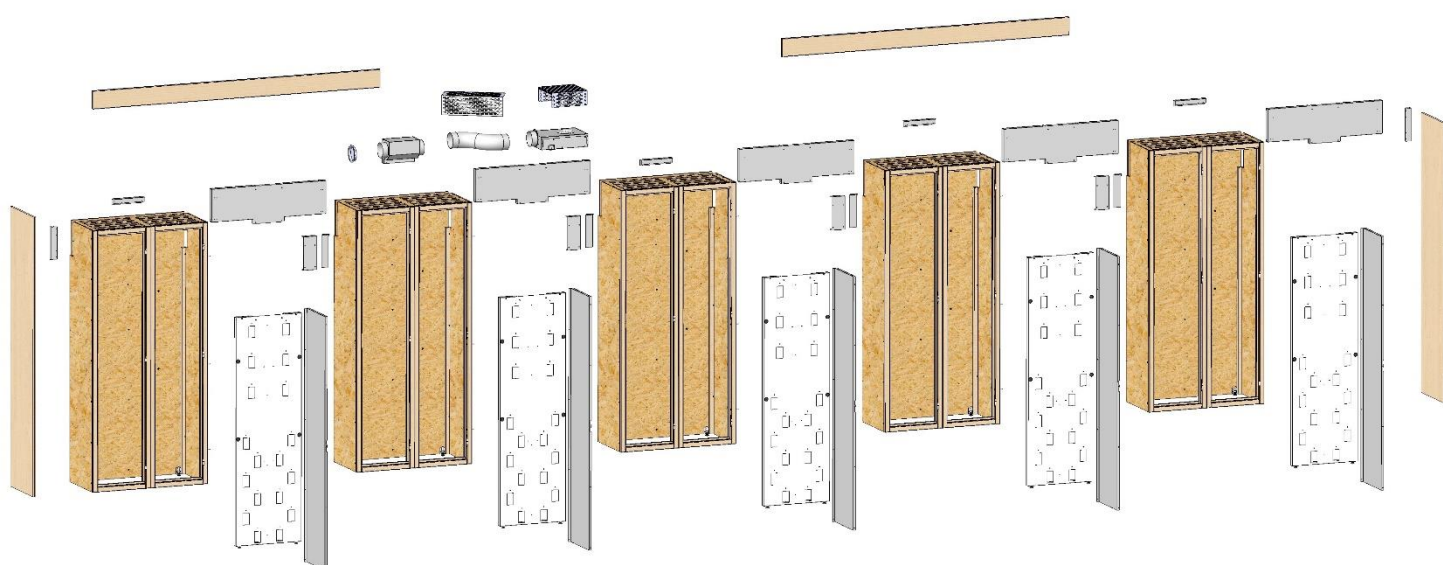

Etape 4 :

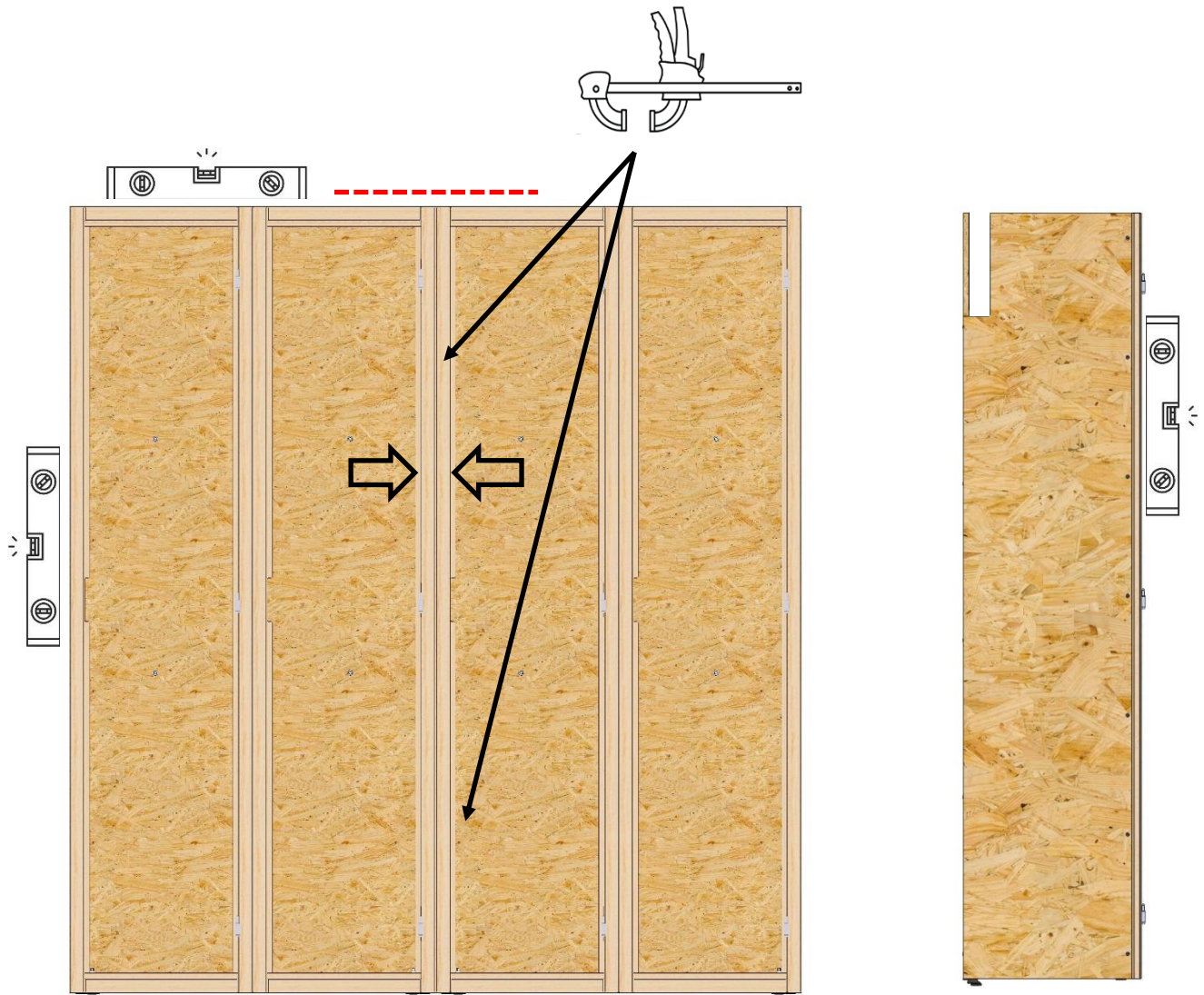
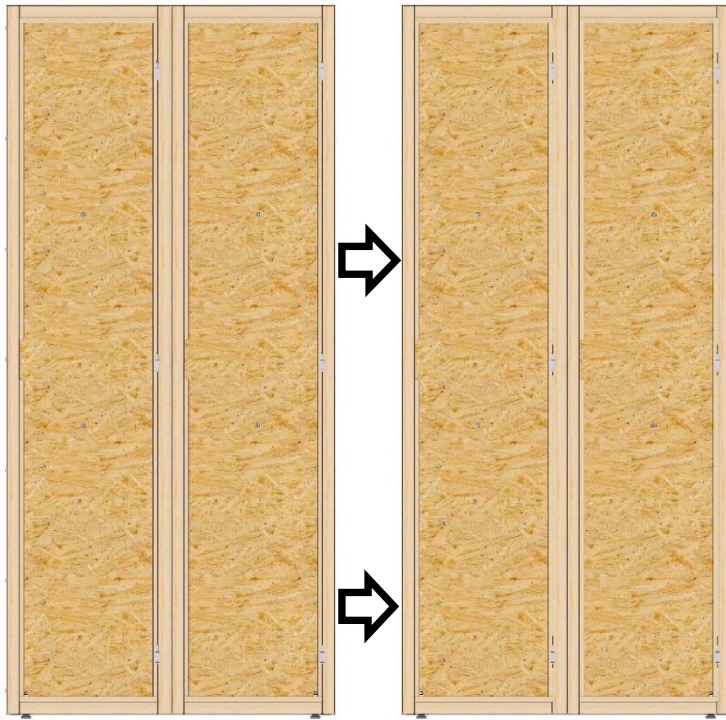

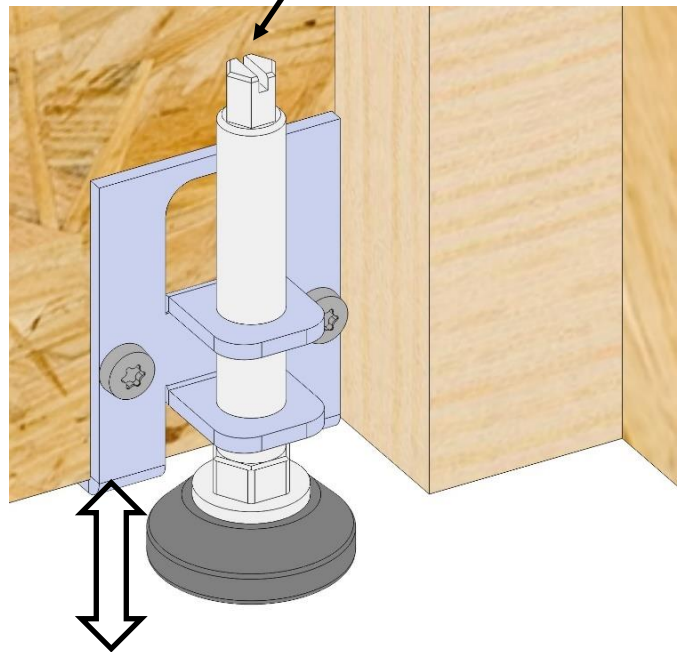
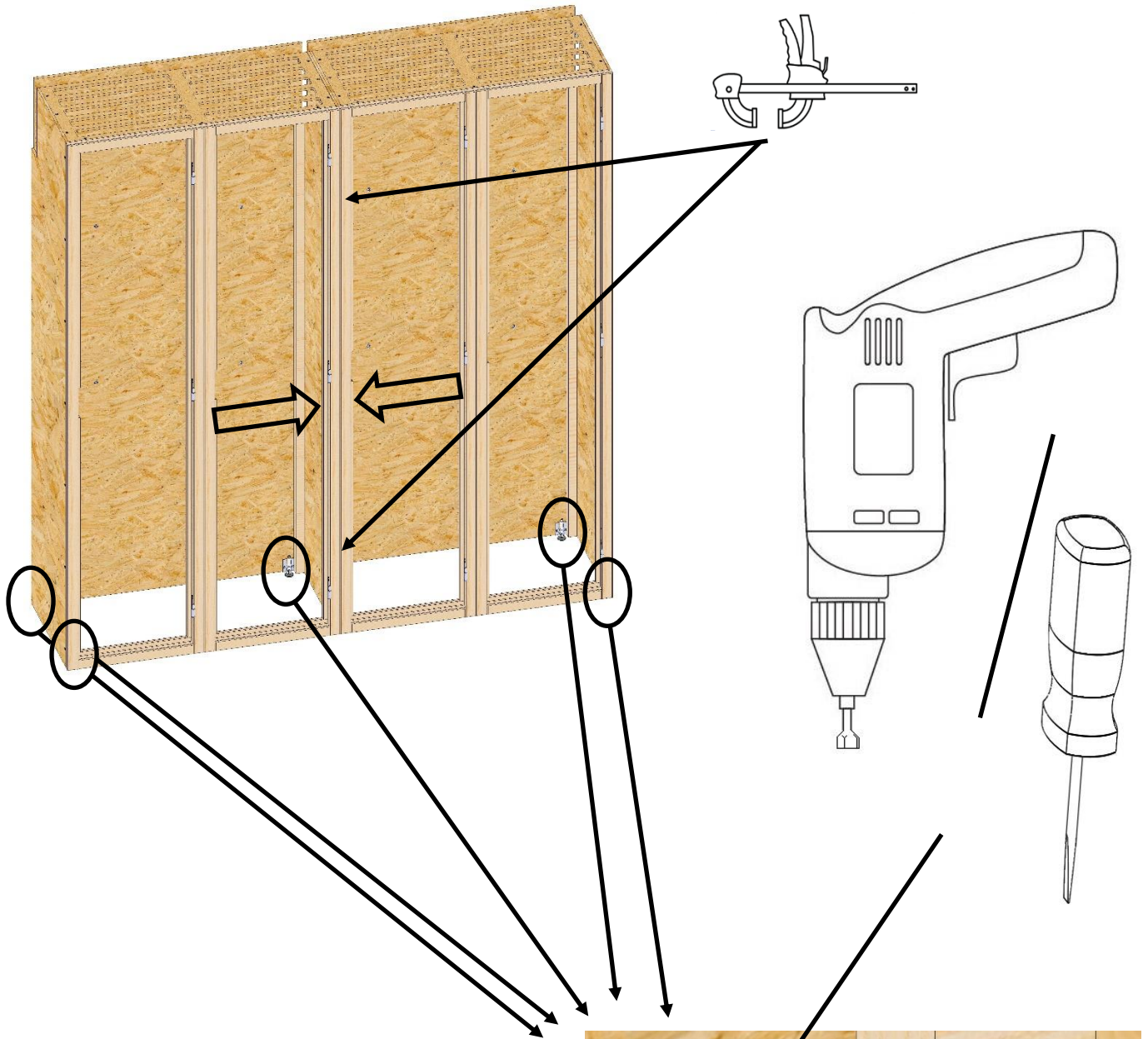

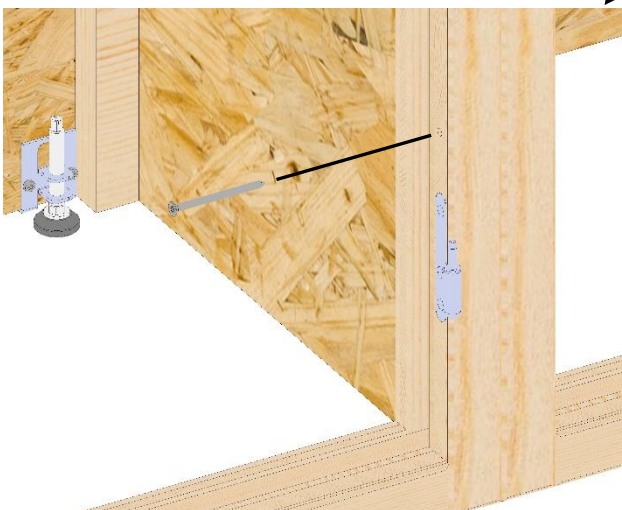
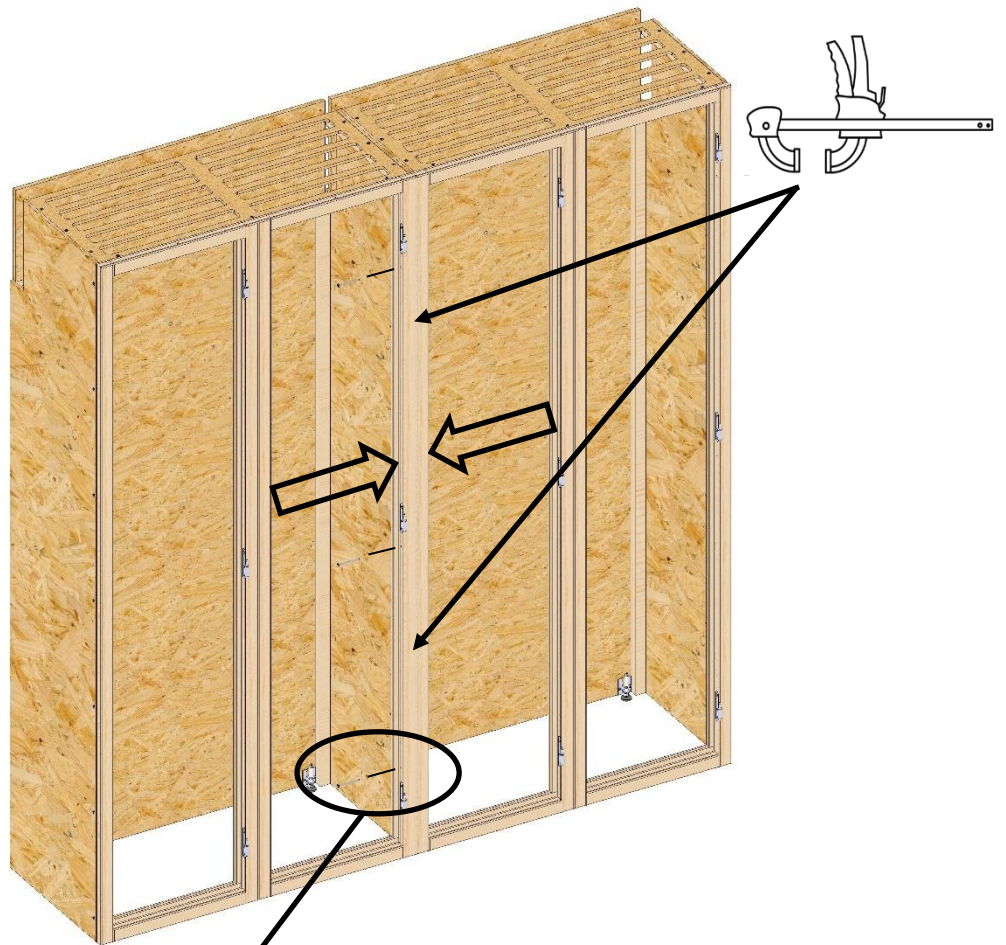
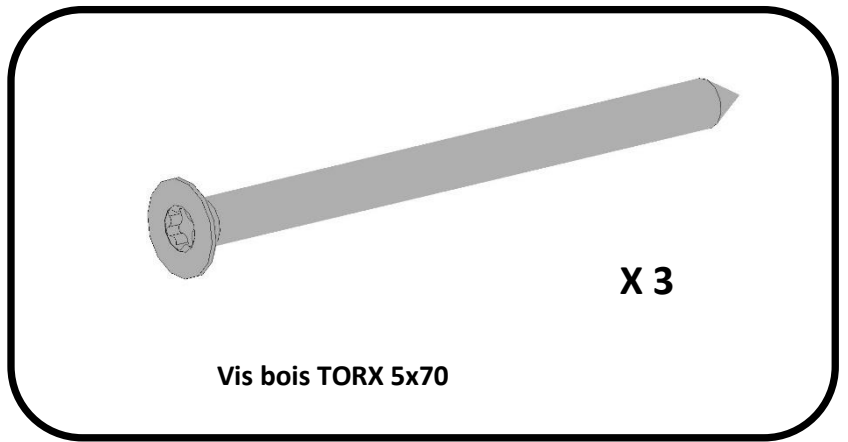

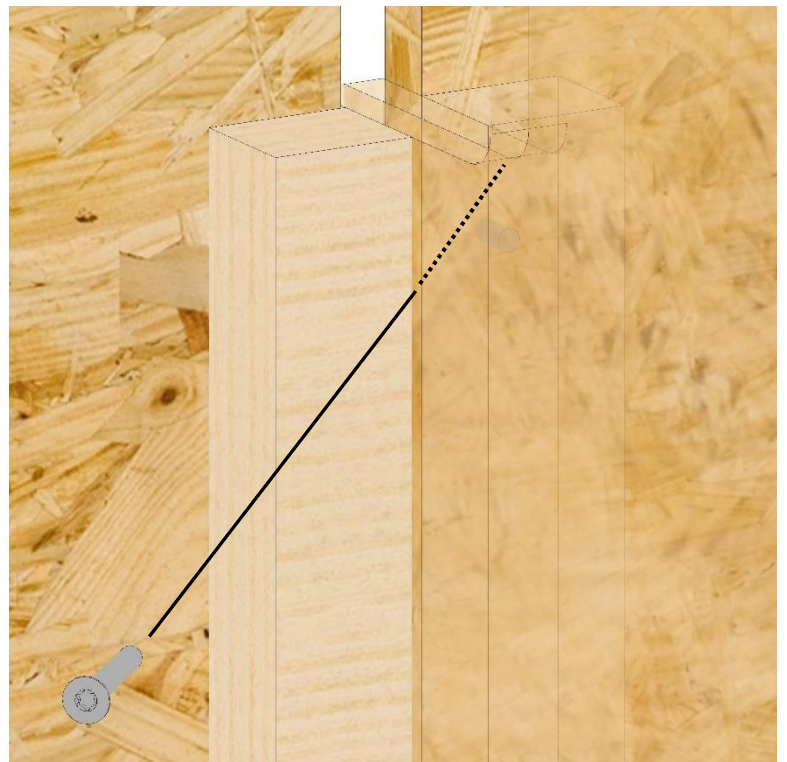
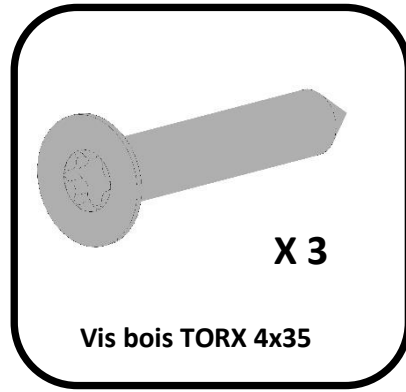

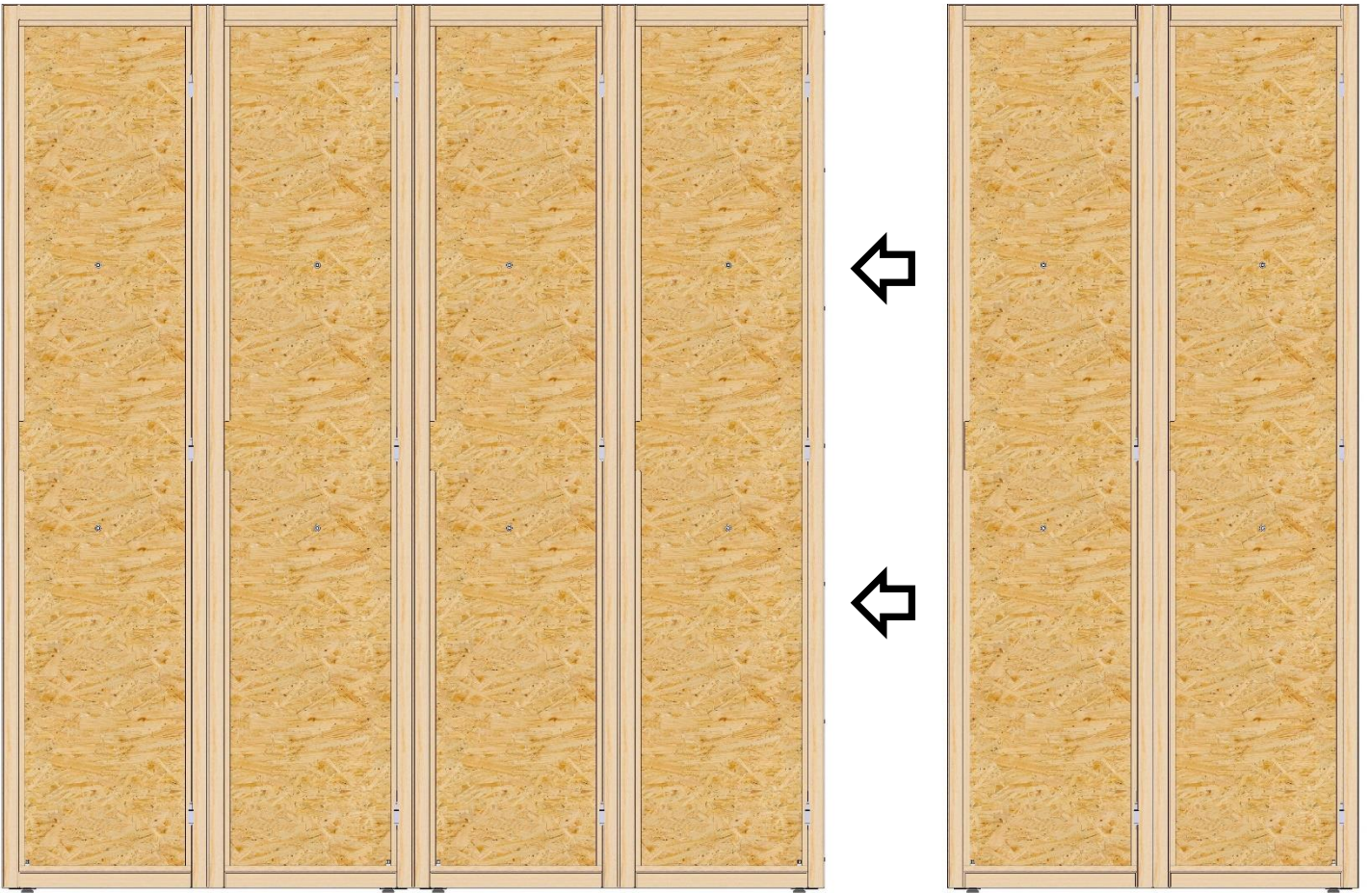

Etape 5 :

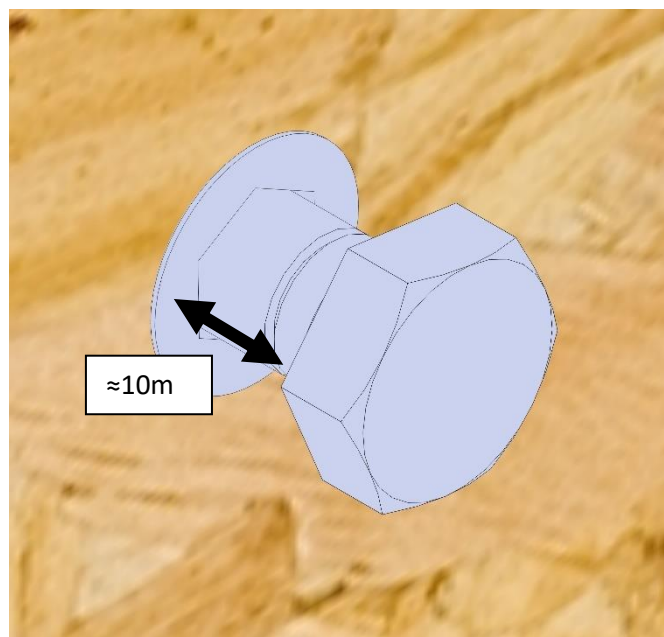
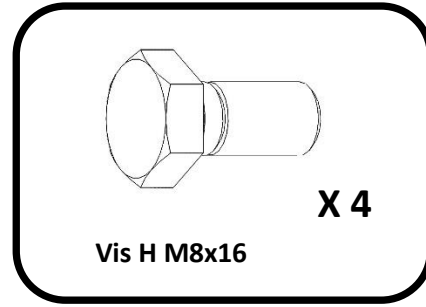

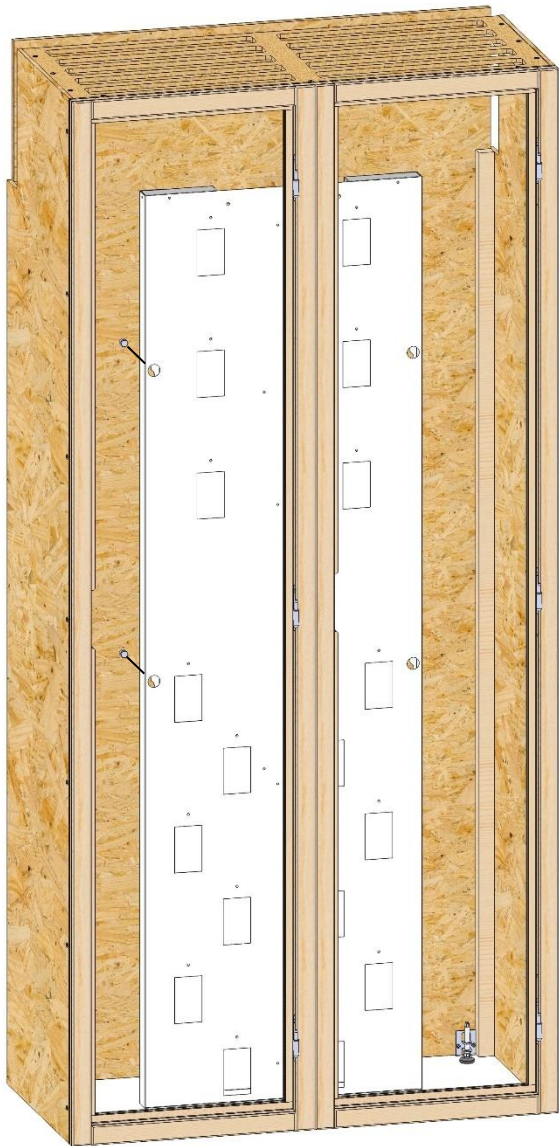

NOTA : ne pas serrer les vis

NOTE : do not tighten the screws

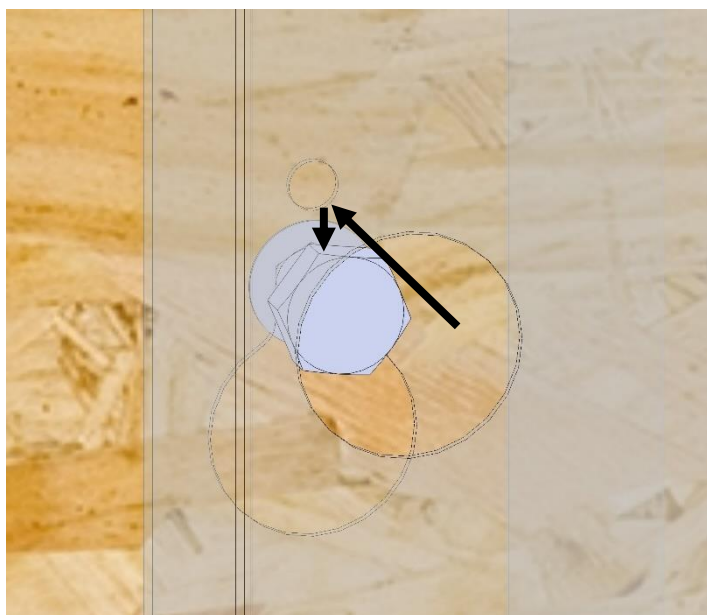

Etape 6 :

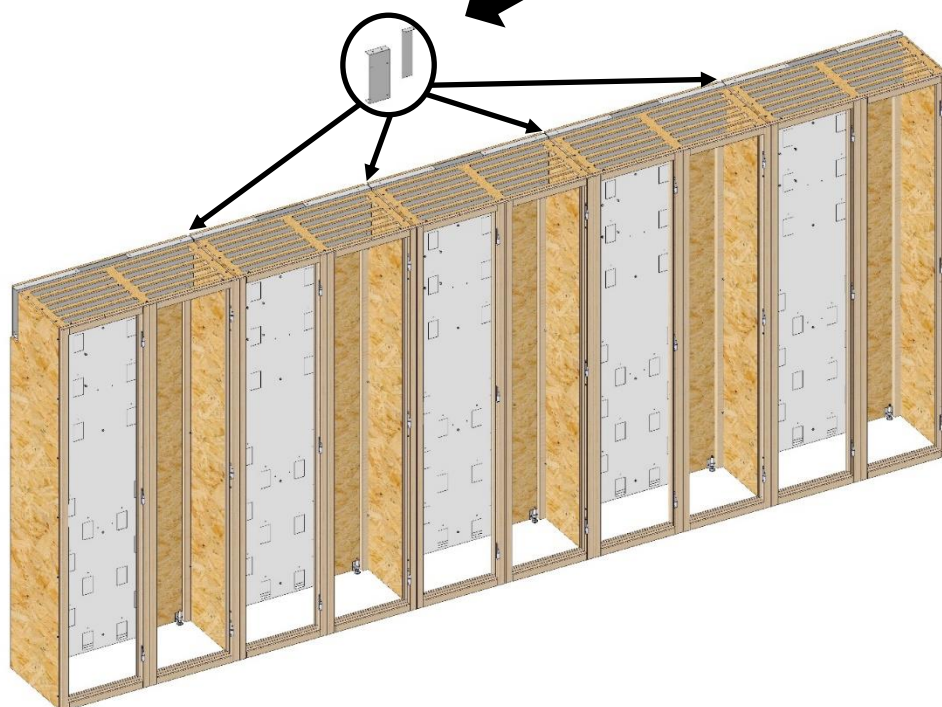
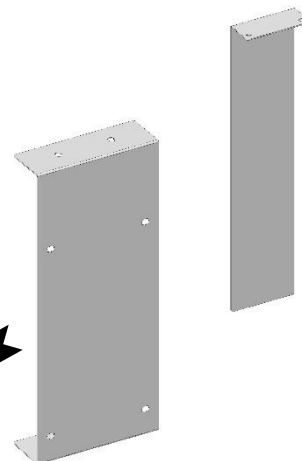
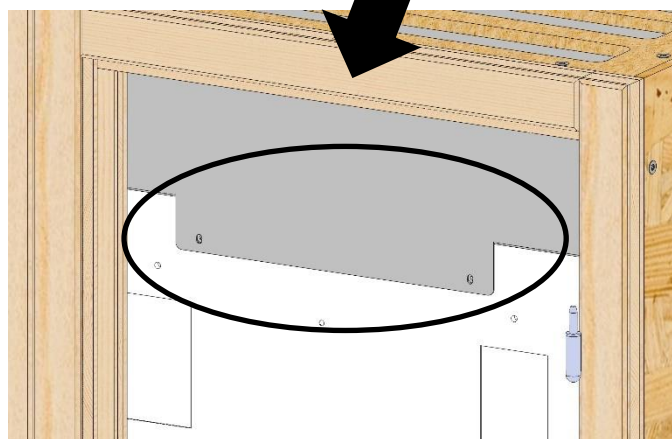
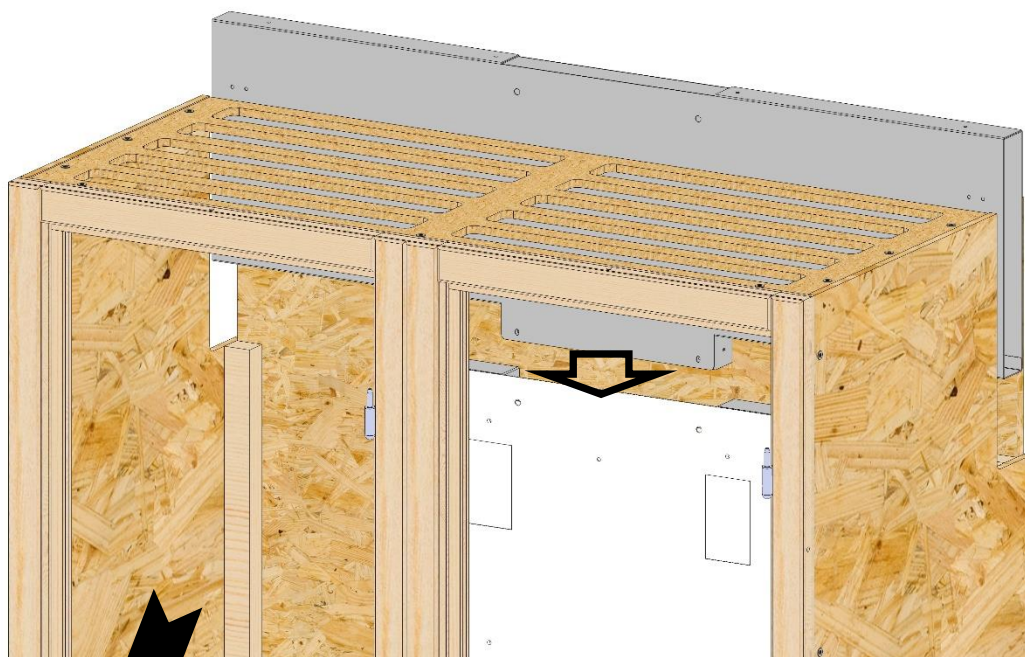

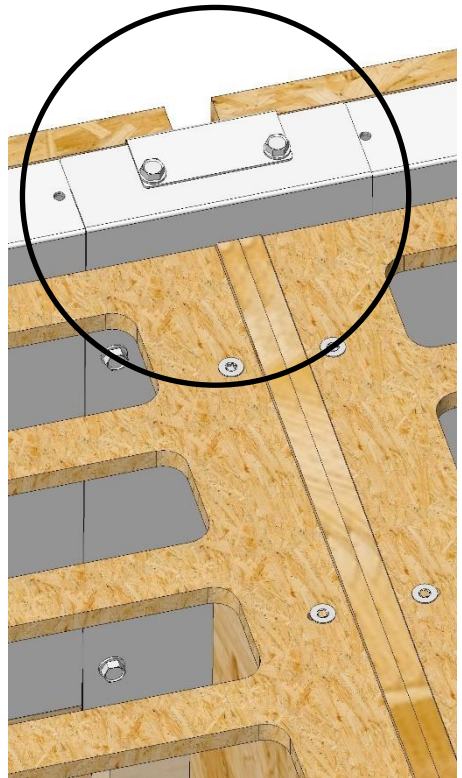
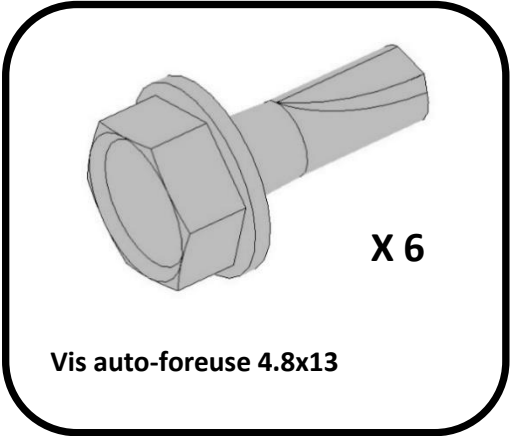
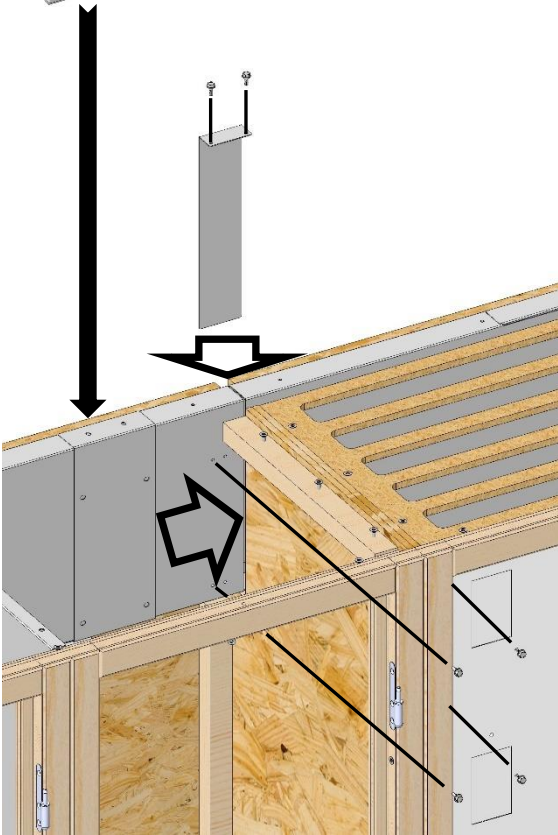
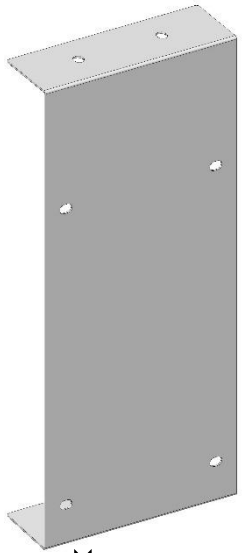

Etape 7 :

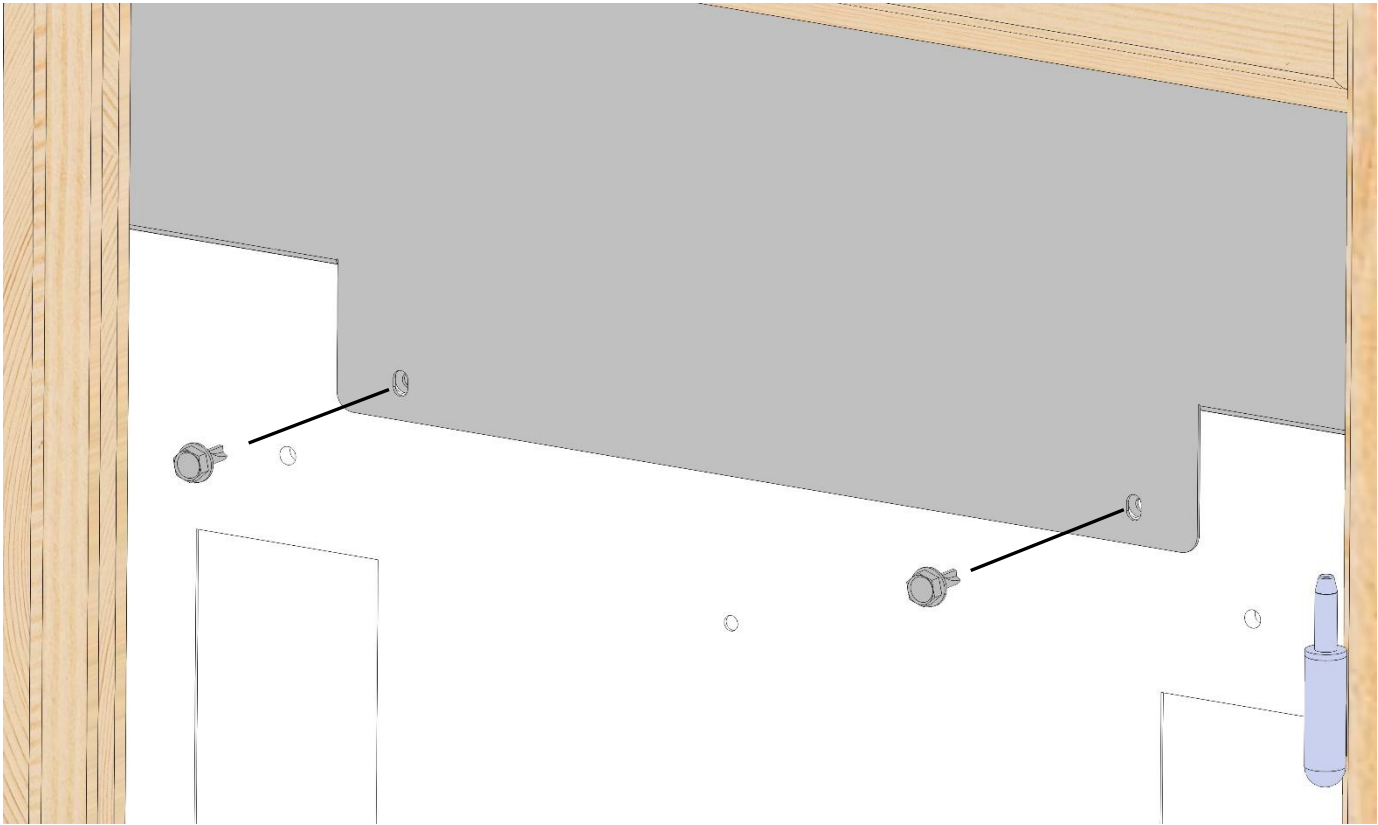
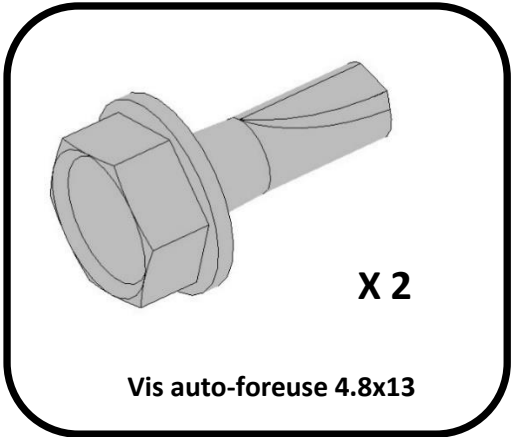

Etape 8 :

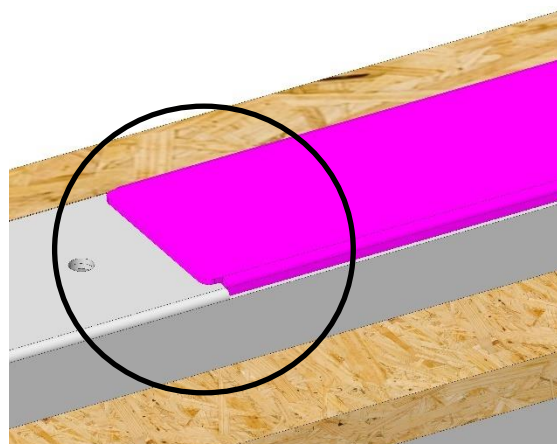
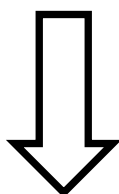
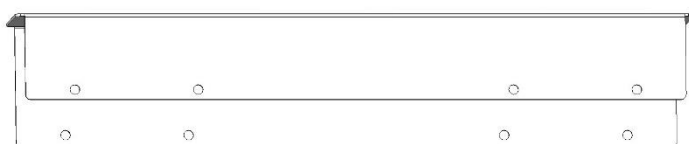
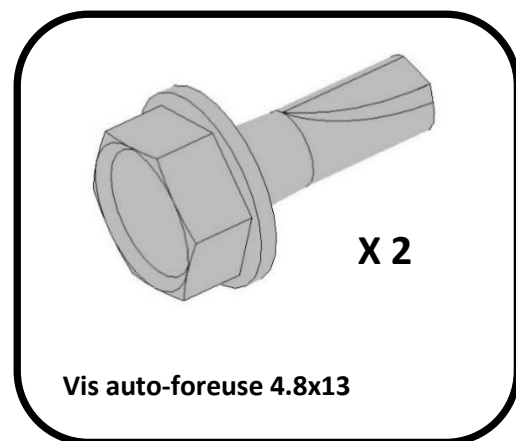
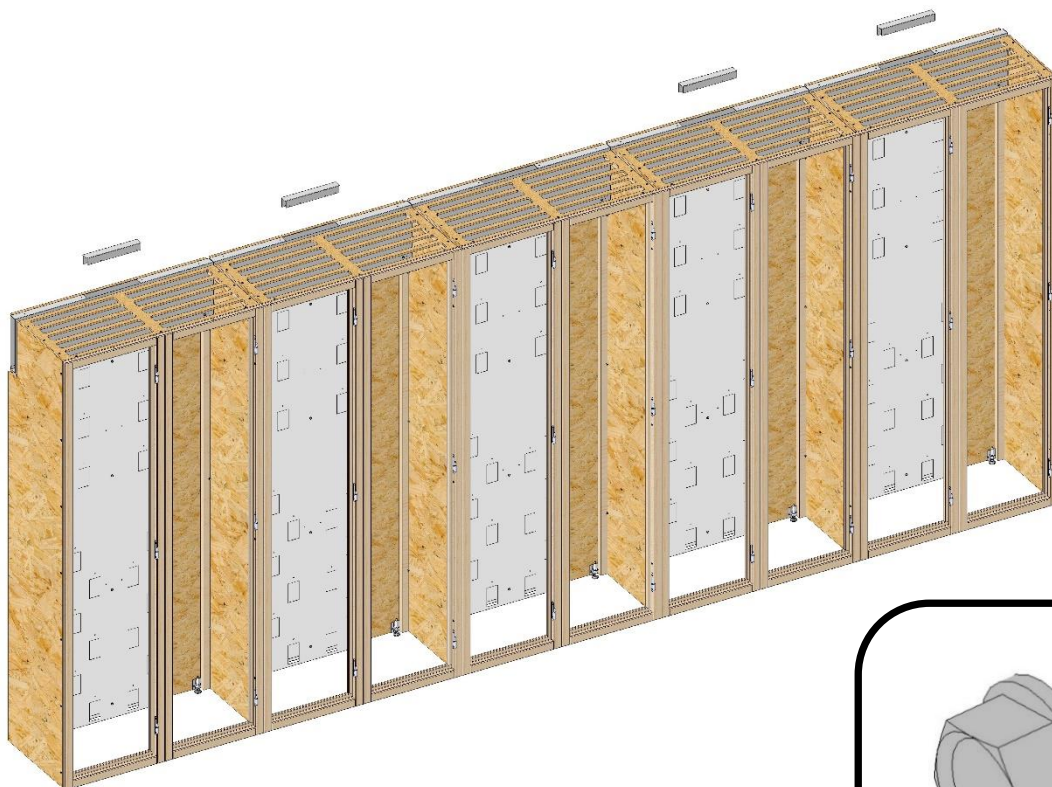

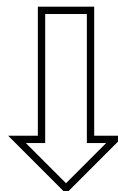
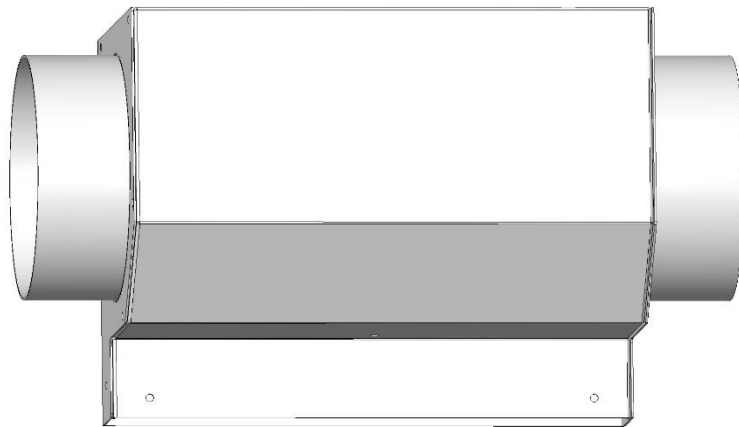
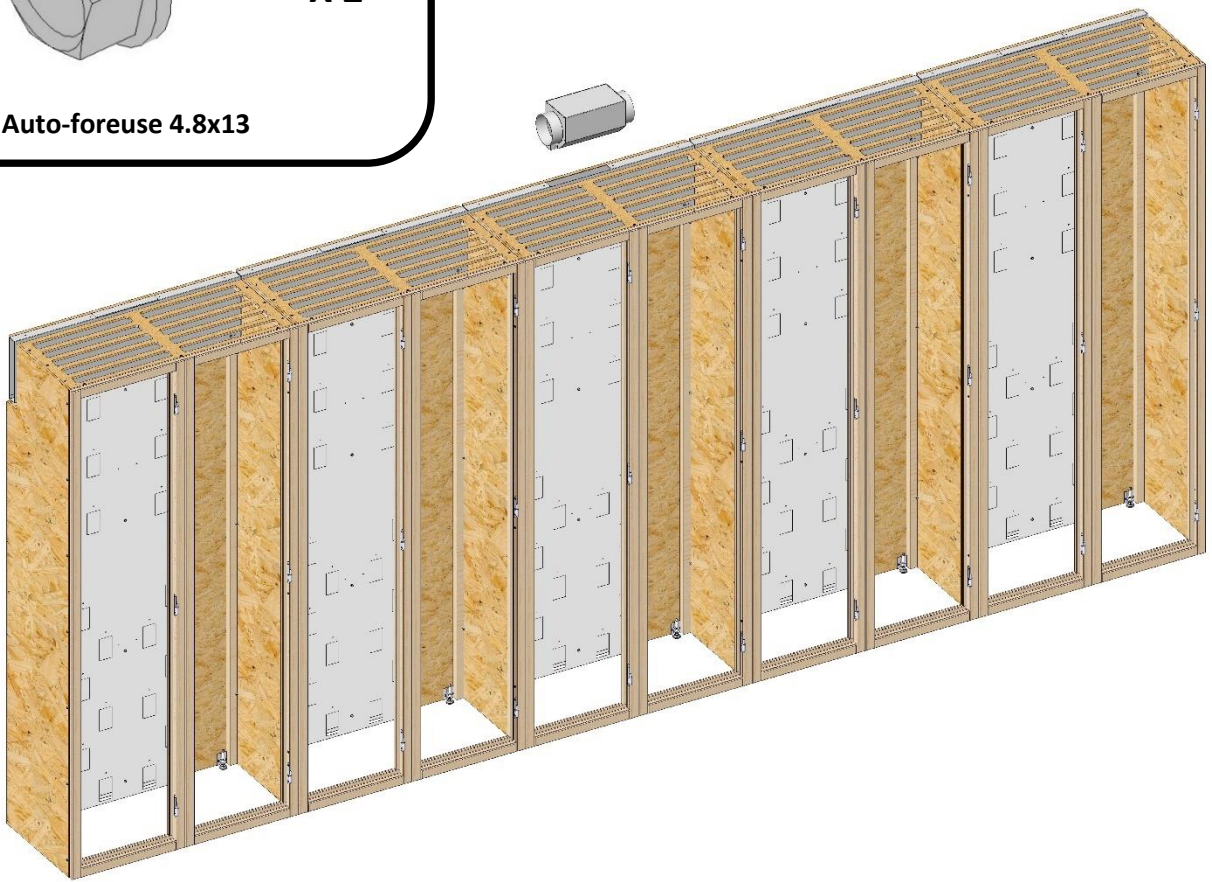
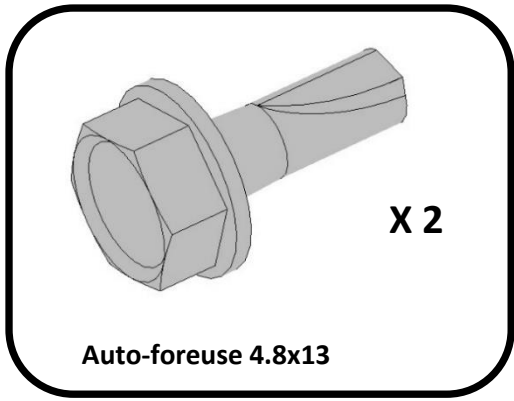

Etape 9 :

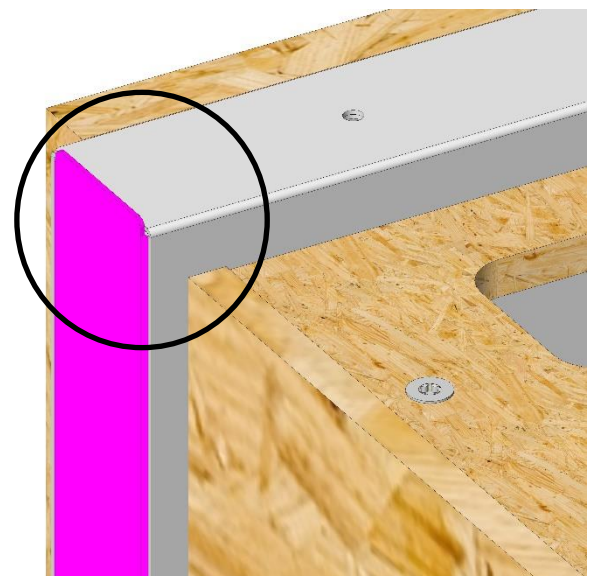
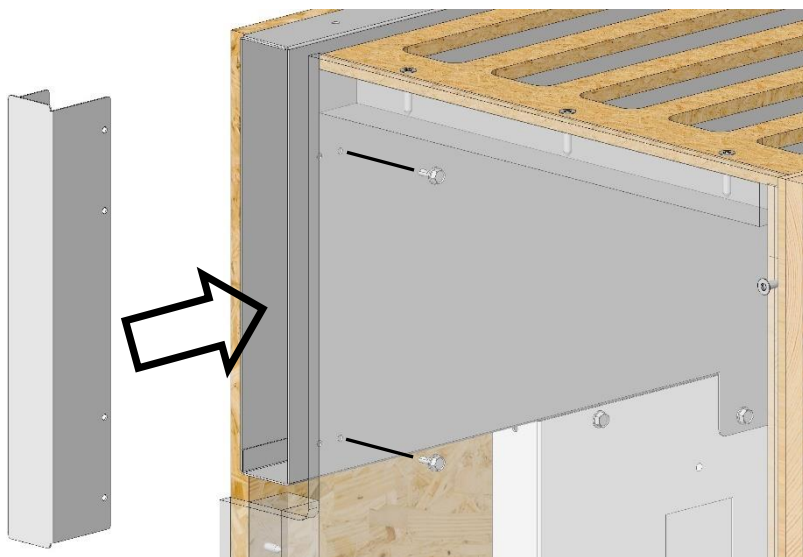
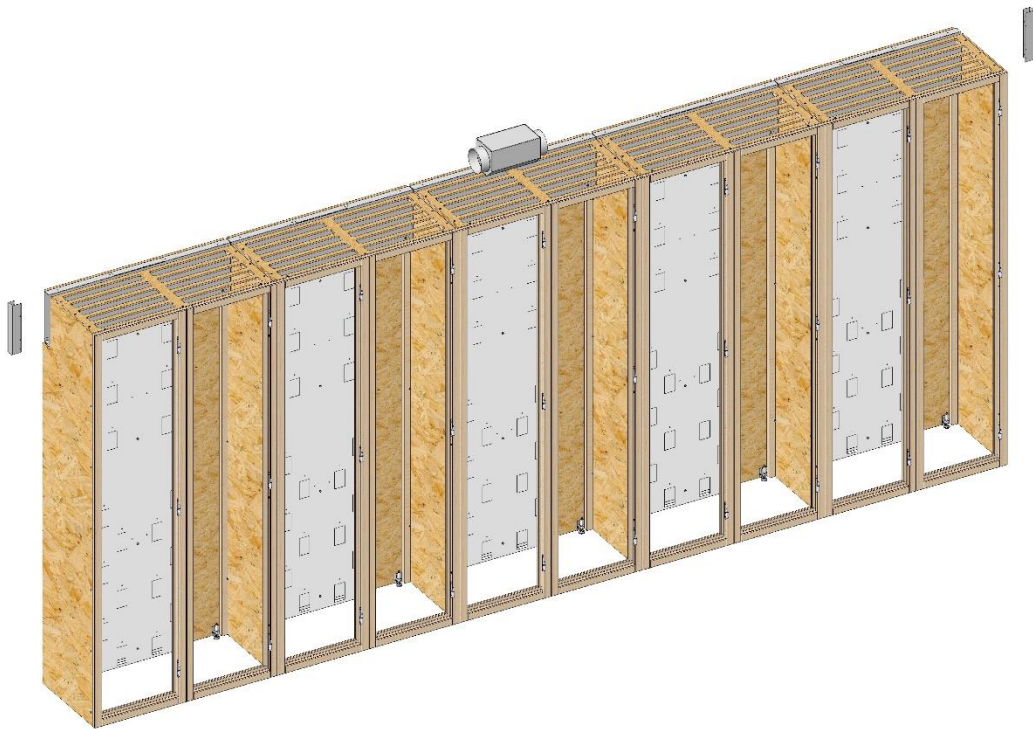
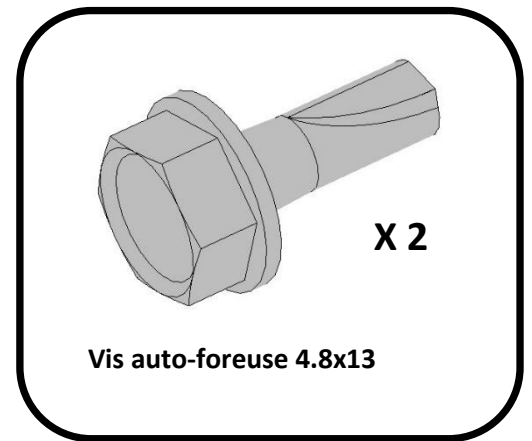

Etape 10 :

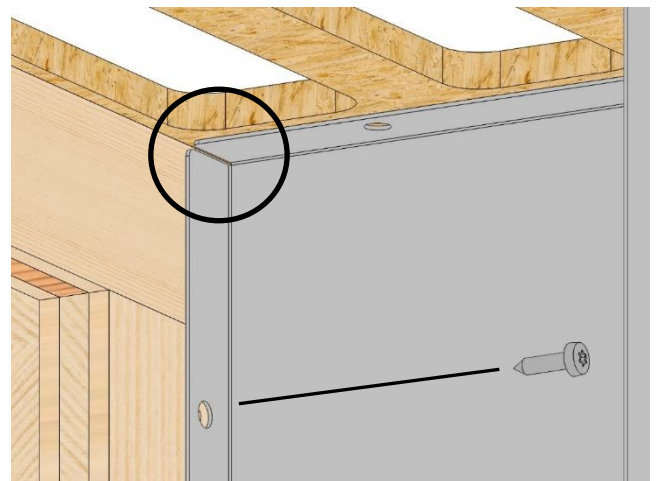
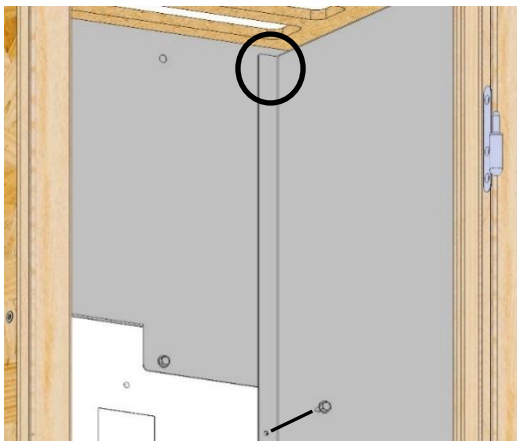
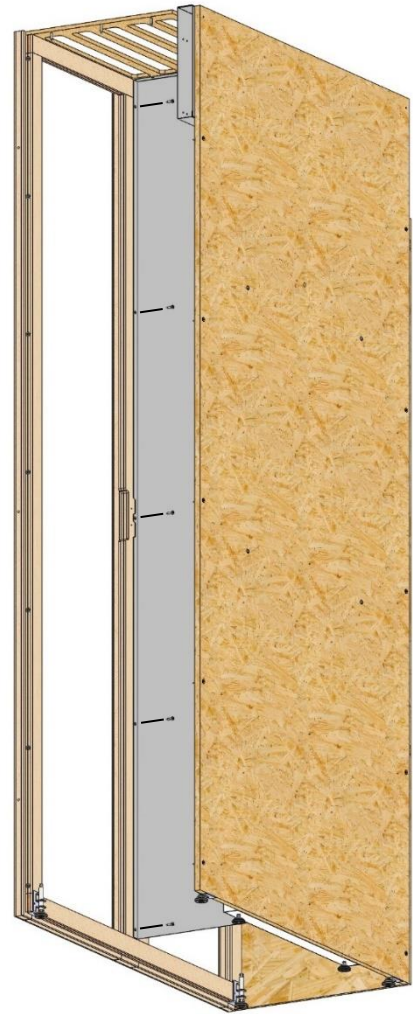
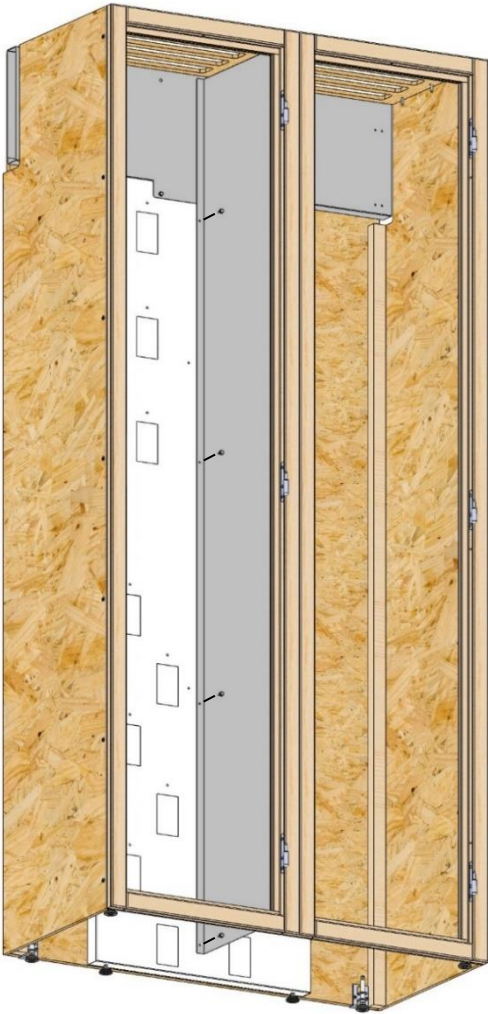
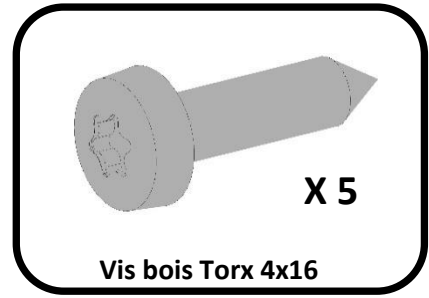
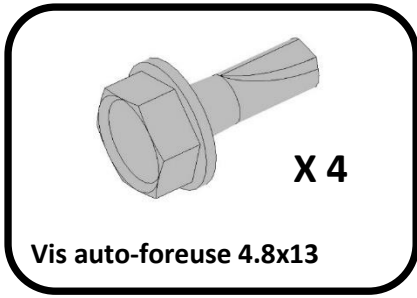

Etape 11 :

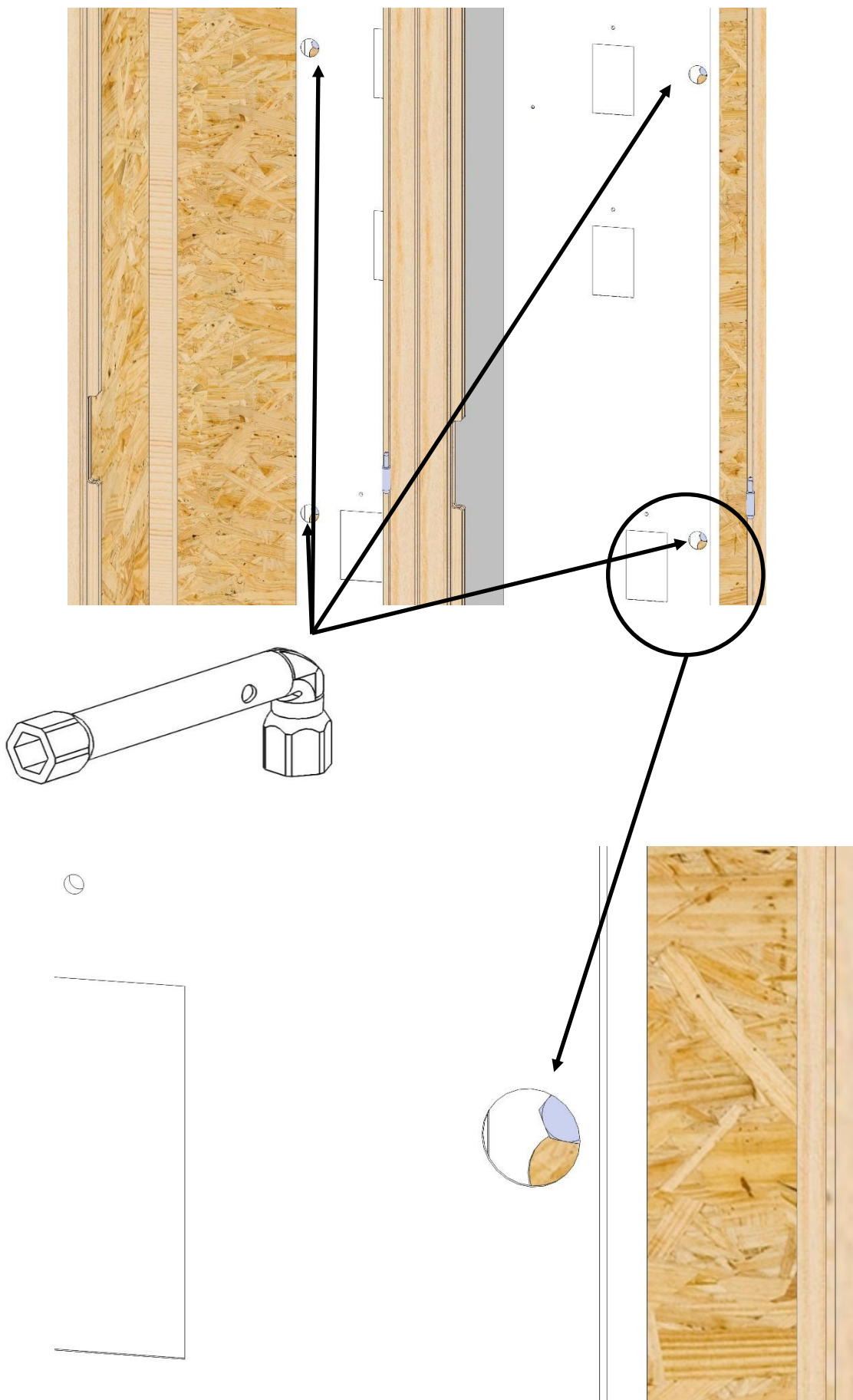

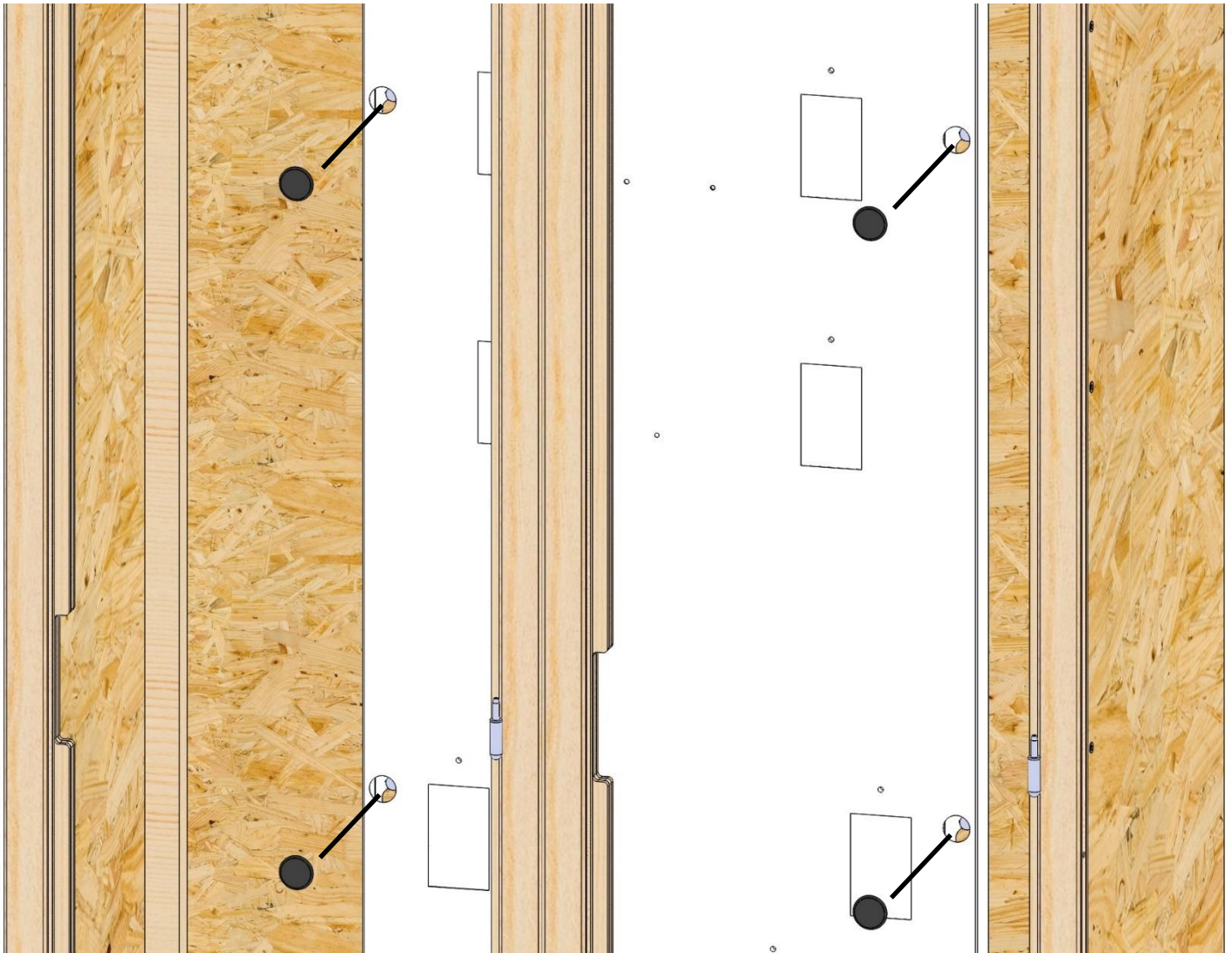
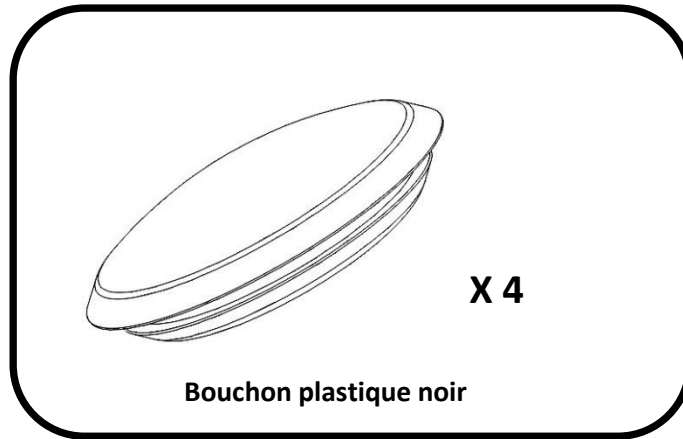

Etape 12 :

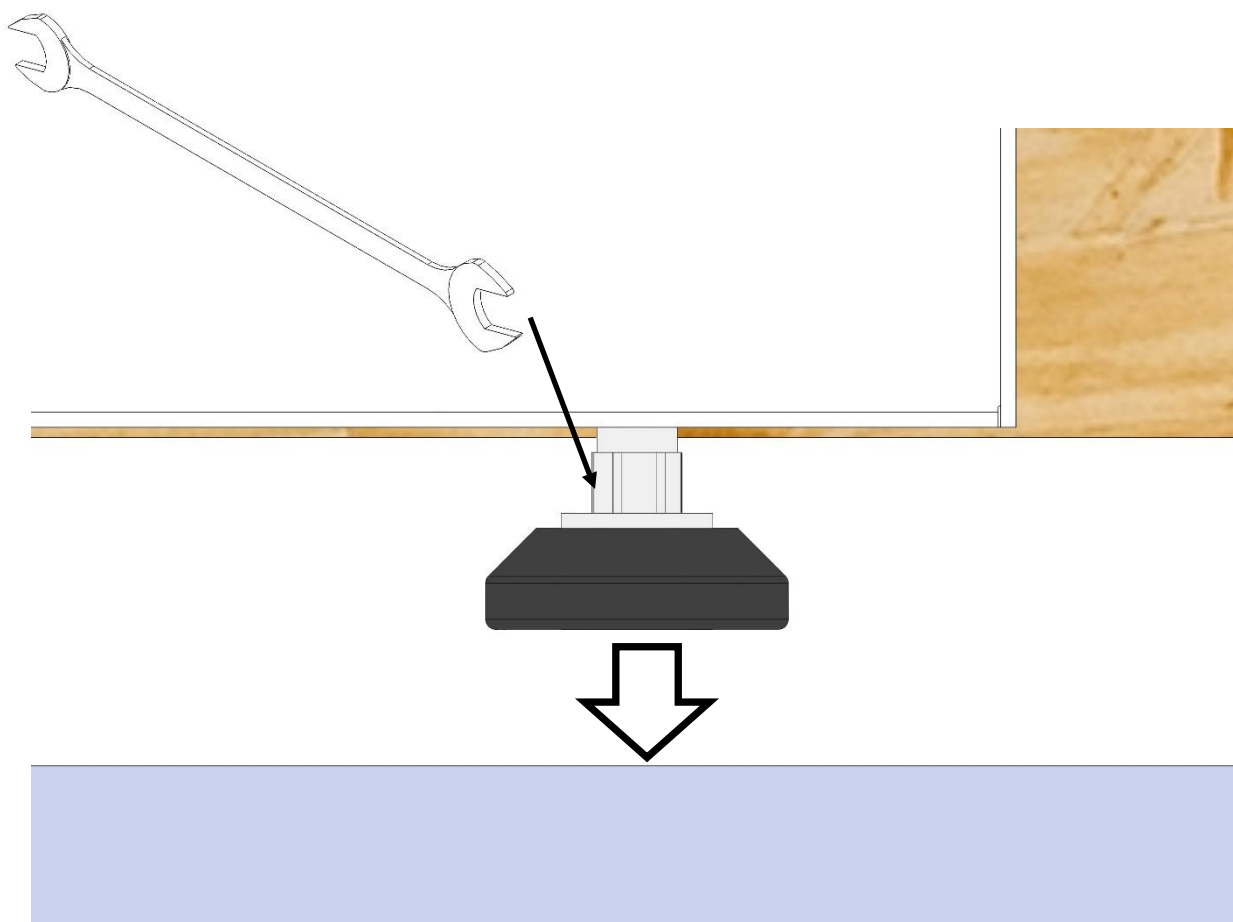
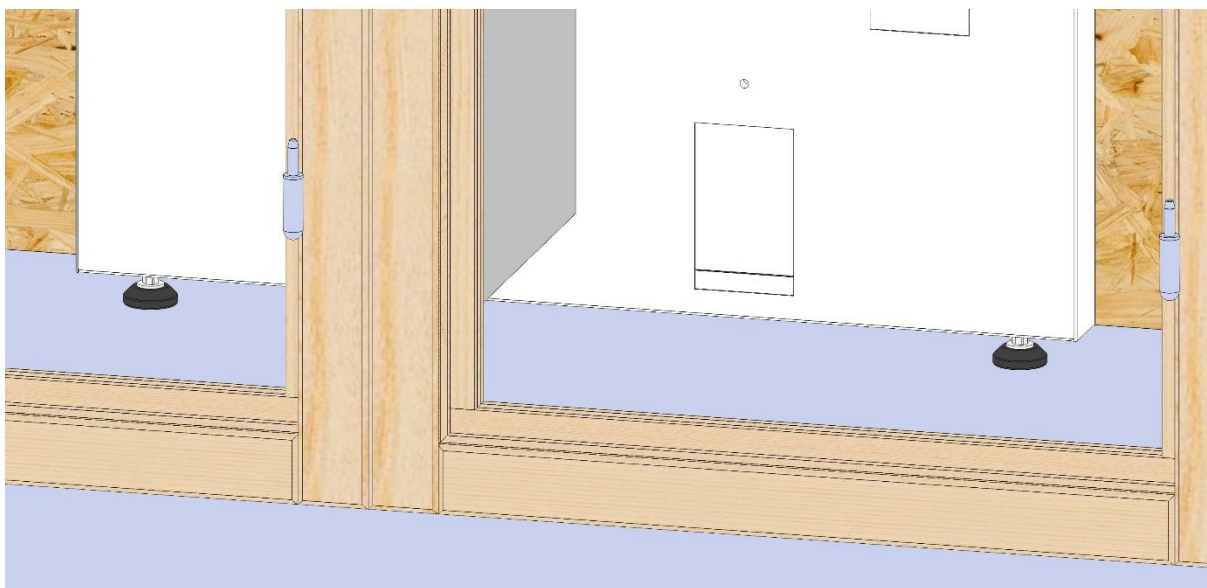

Etape 13 :

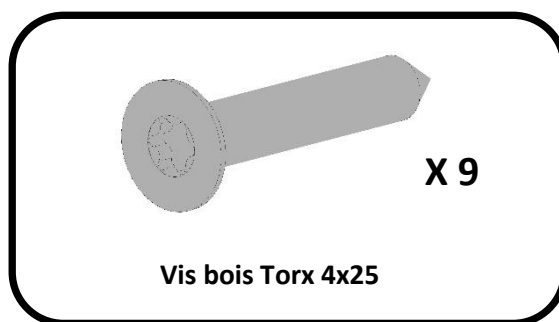
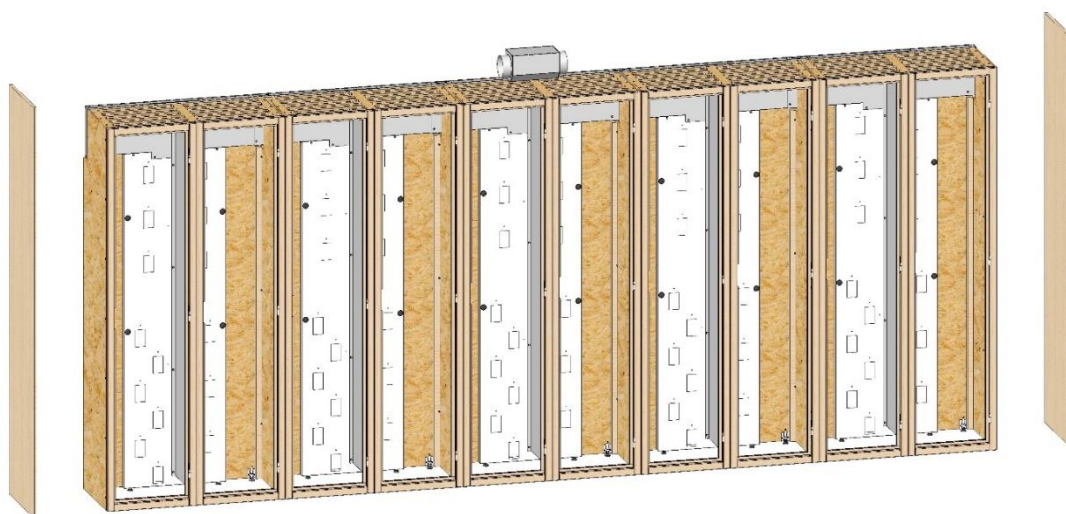

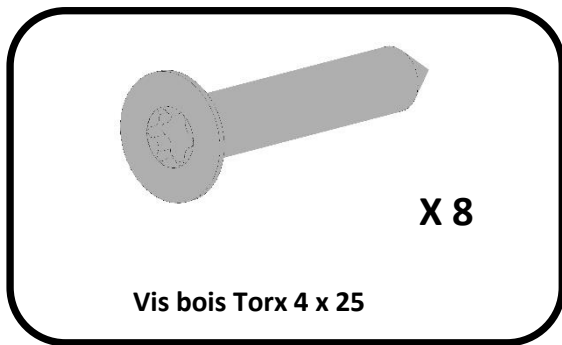
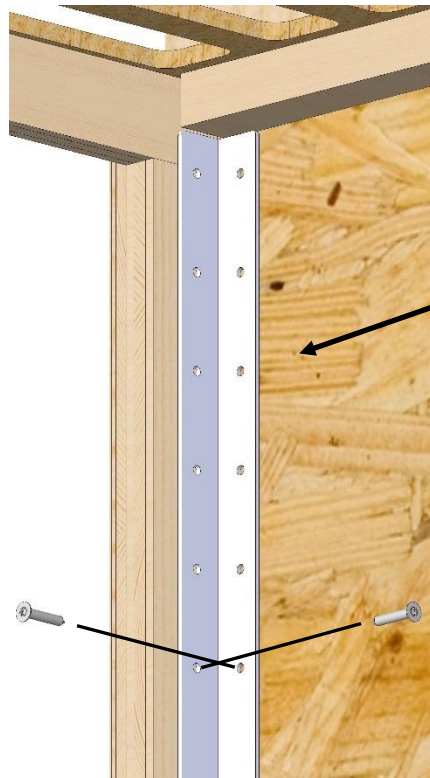
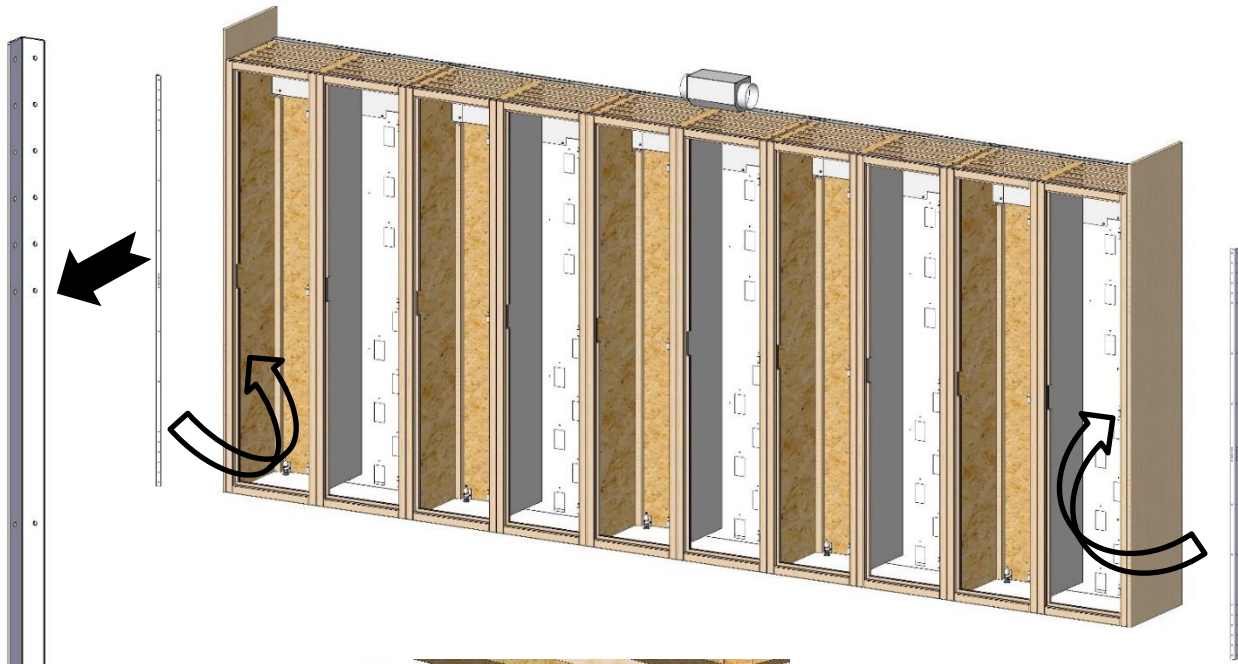

Etape 14 :

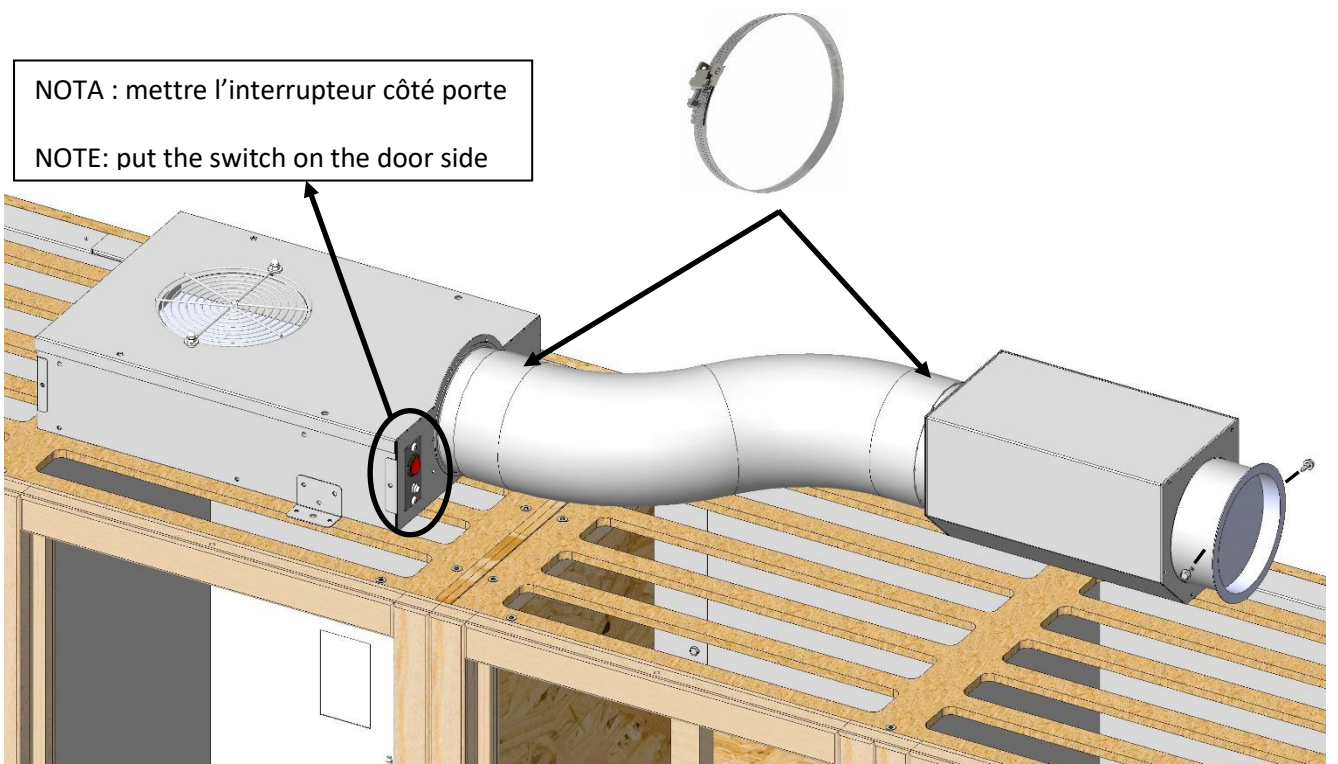
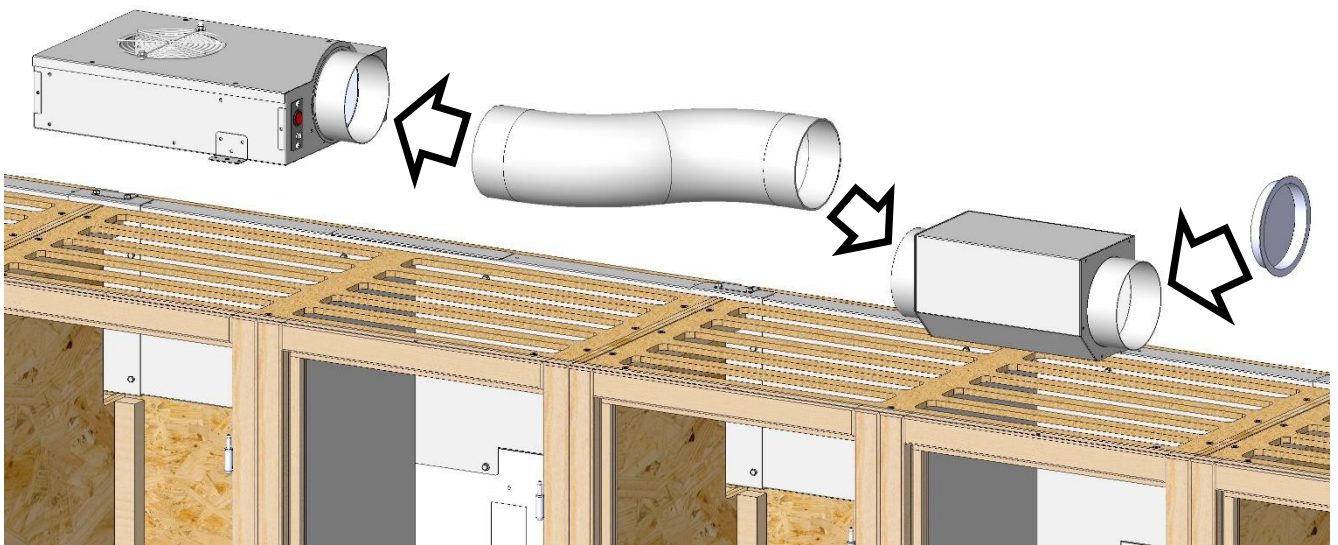
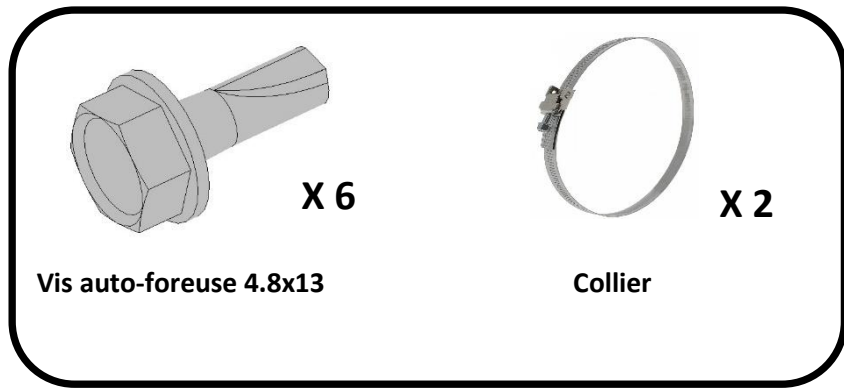

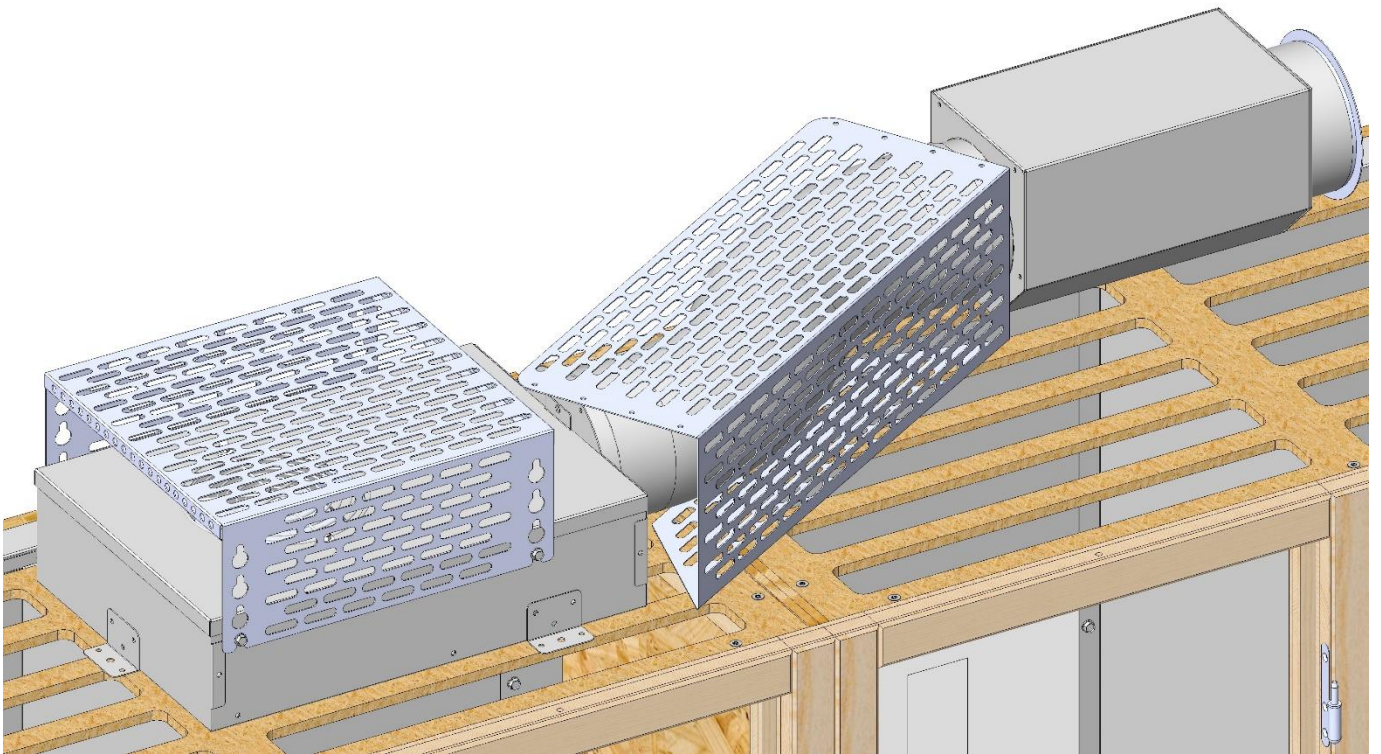
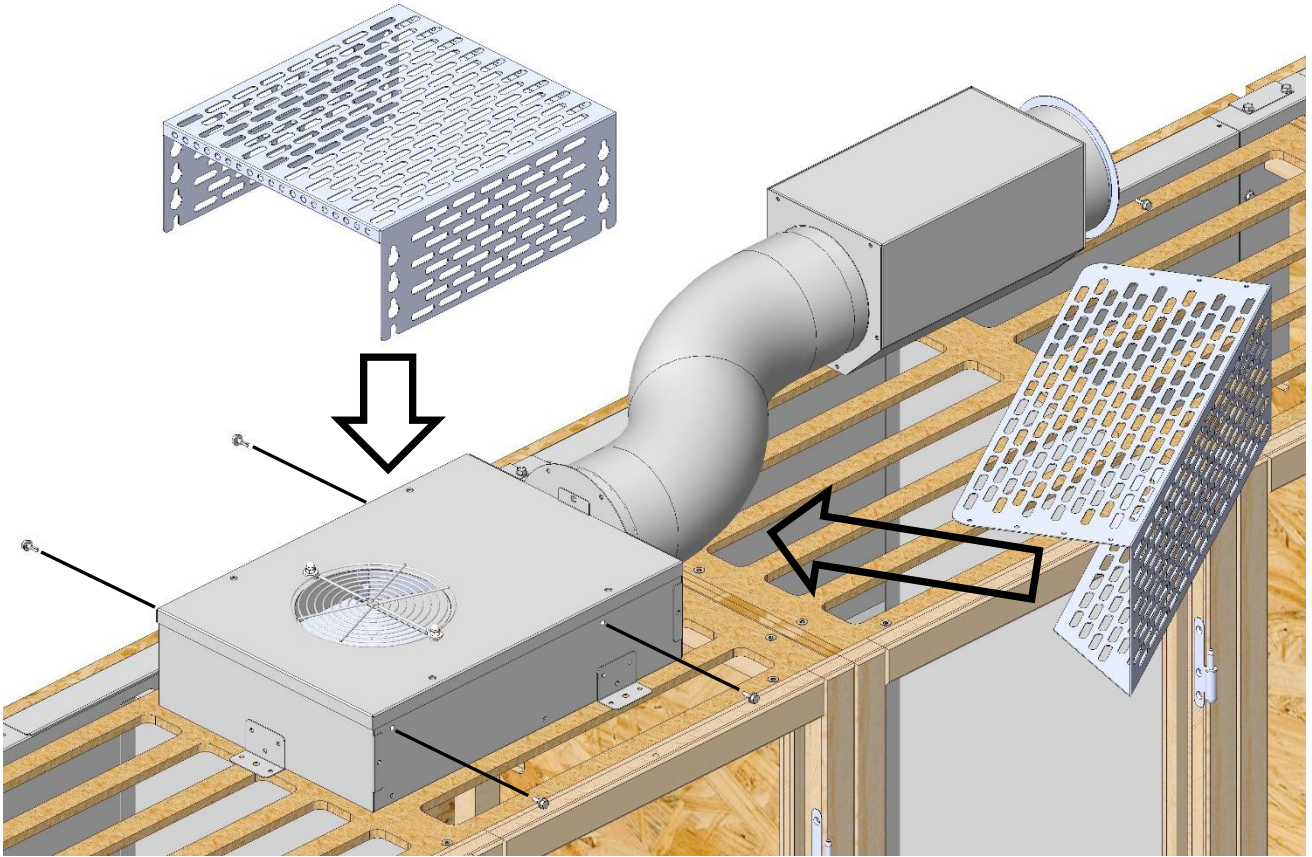

Etape 15 :

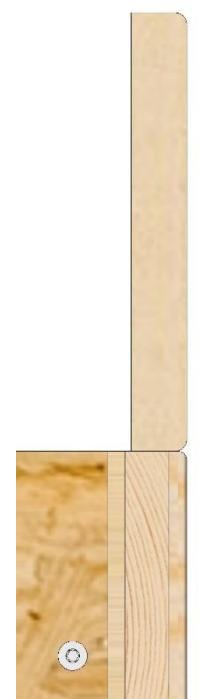
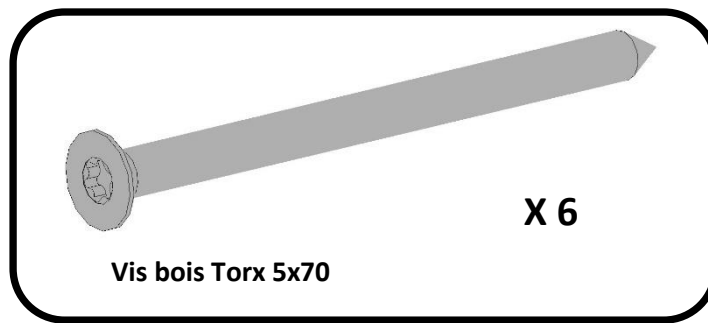

SKI SOLUTIONS SAS

500, route du Ruisset
38360 Noyarey
France

Tél. +33 (0)4 76 26 76 84

Fax. +33 (0)4 76 26 65 09

info@koralp.com

www.koralp.com